

**A MESSAGE  
FROM  
FORREST WOOD...**

Congratulations! As the owner of a new Ranger® boat you have shown that you are a knowledgeable buyer. Ranger has earned the reputation of being the leading manufacturer of quality fishing boats and your investment can, with care, retain its value while giving excellent service through the years.



This manual is intended to help you better understand your boat and make basic care and maintenance quite simple. Additionally, it provides information that could be essential to its safe operation. Please take the time to study this manual along with your engine operating manual before operating your boat.

Should you have questions, contact your Ranger dealer or contact us at

Ranger® Boats  
P.O. Box 179  
Flippin, AR 72634  
(870) 453-2222

Please let me remind you that pleasant boating is safe boating and the very best safety rules are your COMMON SENSE and SOUND JUDGEMENT.

Thank you for becoming a part of the "Ranger Family"!

Sincerely,

*Forrest L. Wood*  
Forrest L. Wood  
Founder

## **GETTING TO KNOW AND HANDLE YOUR RANGER BOAT...**

Your Ranger dealer should see that you have selected the proper horsepower engine for the rating range of the boat model you have chosen. The proper engine mounting height has been selected for optimum performance and the correct propeller has been chosen.

Since most boats spend more time on the trailer than in the water, a RangerTrail® trailer can extend the useful life of your new boat. The load **MUST** be evenly distributed on the properly fitting “bunks” or “pads” of the trailer. The boat should not rest on the loading rollers, but should properly cradle on the bunks.

Always park your rig so that the trailer tongue is higher than the stern of the boat, so that any water can drain from the hull when the drain plug is removed. All livewell valves should be placed in the “empty” position to properly drain your livewell plumbing.

A properly fitted boat cover will protect your investment from the damaging effects of the ultraviolet rays of sunlight, as well as from road film, rain and dirt abrasion while trailering. The cover also protects your accessory equipment and fishing tackle from “prying eyes” and helps to guard against pilferage.

Familiarize yourself with the instruments and indicators used with all installed equipment. Factory equipment manuals are included to assist you to properly operate your trolling motor; depth finders; engine tachometer; speedometer; and any additional accessories that you have installed. Naturally this Ranger manual is only complete when you have completely studied your engine operating manual and are familiar with engine operation.

Now you are ready for a ride in your new boat! This will be an exciting, fun experience if you exercise the proper caution and observe all safety rules and regulations.

Before launching your boat... stop on the ramp short of the water. Stop your vehicle's engine and set the parking brake. At the rear of the boat, install your transom drain plug and remove the trailering tie-downs, trailering arms, motor supports and/or support brackets. Slowly back the boat and trailer into the water and unhook the winch strap hook. When in the driver's seat, put on and secure your life vest and attach the engine emergency stop switch lanyard to your person. Start engine and back your boat off the trailer. You should experience no problem if the water is adequately deep for proper launching.

While you are easing along within the “No Wake” zone you should trim your engine all the way down to its lowest position (in). Turn the steering right and left to insure that there is no undue slack and inspect the steering system. Look for any loose connections at the engine and beneath the driver’s console (see pp. 24-28). Inspection of this crucial linkage system can be visually made at home or at the lake, but should be done at regular intervals. Before applying power and “opening it up”, insure that all passengers are properly seated and are wearing an approved Personal Flotation Device (PFD or Life vest). Check to see that there are no obstructions in your path. We recommend that the front pedestal seat be removed from the front deck base and positioned in the special base provided in the front floor of the boat. If your boat has non-adjustable pedestals, remove the extension pipe from the seat base and install the seat base directly into the front deck receptacle. If your boat has an optional deck extension and power pedestals, remove the lid in the deck extension and secure the pedestal in the receptacle provided in the floor. If the optional deck extension does not have a removable lid, store your seat securely in the floor of the boat. This will provide for an unobstructed view while driving. The power pedestal should be pushed down into the lowest position. Should there be no base provided in the floor, the seat should be removed and securely placed in the floor of the boat.

When you have cleared the “No Wake” zone it is time to accelerate and get your new boat “on plane”. Before applying power, insure that all passengers are properly and securely seated in appropriate locations. Abruptly move the throttle lever into the full open position (full forward). The bow of the boat will rise into the air for a moment... this is normal operation when a boat is “coming out of the hole” and is no cause for alarm. The bow will quickly come back down into a level running position. When the boat begins to accelerate rapidly, the throttle should be pulled back to obtain a comfortable running speed. Always increase your speed a little at a time until you are running at a speed at which you feel safe and are in complete control...**NEVER FASTER THAN YOUR EXPERIENCE DICTATES!** At this moderate speed you should begin to trim your engine into a higher position (out). Please refer to your engine owner’s manual for more information on power trim use and operations. Your speed will increase and the bow will lift. The boat will begin to run with the back rear portion of the hull in contact with the water and steering will become easier. Over-trimming will result in excessively high RPM (note your tachometer) and the steering can develop “torque” or a “pull” toward the right. Trim back down slightly for best operation. A different trim

setting (see your trim indicator) will be required for different throttle settings. You will soon develop an instinctive feel for these settings. Your ear will become attuned to the sound of the proper engine RPM. Again, over trimming is to be avoided as excessive RPM can cause engine damage and can also cause your prop to “blow out” (lose its grip on the water because it is too near the surface). If the bow of your boat should begin to bob up and down (called porpoising) you will probably have over trimmed. Bump the trim button down a little until the motion stops.

 **WARNING** Improper use of power trim may lead to excessive bow steer or steering torque (pull) and could lead to accidental injury or death.

If your boat should continue to “porpoise”, a slight increase in throttle and speed will generally correct the condition. Proper distribution of the load in your boat will make a great difference in its operation. Moving tackle boxes or ice chests rearward or toward the front can greatly effect boat performance and handling.

When beginning a turn with the engine trimmed in the higher positions, the trim switch should be pressed to LOWER the engine further into the water just prior to and during the turning of the steering wheel. Practice and experience will determine just how far down you will need to trim for safely handling a turn at various speeds and water conditions. Just remember to **MAKE SAFETY YOUR GUIDE** when attempting any new or unfamiliar maneuver. Proceed **ONLY AT SPEEDS AT WHICH YOU FEEL SAFE AND IN CONTROL!**

Naturally, it is impossible to describe here all the different situations that you may encounter. Just remember that **COMMON SENSE** is your best safety precaution. Your new boat is built to safely carry you in **NORMAL OPERATION**, but it is up to you to stay alert and to avoid dangerous situations. Safe boating is in the hands of the operator.

Even the pleasant experience of the “first ride in your new boat” must sometime come to an end. Hopefully you have purchased a “drive on” trailer with your boat. The key to simple and effortless loading of your boat is having the trailer in the proper position. This “right” position is determined by the steepness of the ramp. Here, you will have to experiment with the proper depth to have your trailer in. The most common mistake is having the trailer too deep, so a little time spent experimenting with different depth positions can ultimately save you much time and embarrassment. To load at slow speed, position your boat to head directly between the guide bunks or guide rollers and use the thrust

of your outboard engine to drive the boat forward until the bow contacts the roller on the bow stand block. Shut down your outboard and fasten the winch strap hook to the bow eye. Tighten the winch strap and lock winch before pulling the boat from the water. Your engine should be trimmed up into a higher position before the trailer is pulled up the ramp to prevent damage to the lower unit or propeller. Pull the rig up the ramp and park well out of the way of other boaters. Stop your vehicle engine and set parking brake. Remove the drain plug, open and drain the livewell systems, and stow all loose equipment. We recommend that you install a transom saver, or engine support brace, between the trailer frame and the lower unit of your engine to prevent damage to your transom while the boat is in transit.

For the most possible boating and fishing enjoyment familiarize yourself completely with your boat and with the instruction manuals for all additional equipment. If you are a novice, there are publications on good seamanship recommended to make your boating safe and enjoyable. We also recommend that you enroll and attend any of the excellent safe boating courses offered and conducted by your area Power Squadron or the U.S. Coast Guard Auxiliary.

 **WARNING** The operator (driver) is responsible for the correct and safe operation of the boat, the equipment aboard and the safety of all occupants aboard. We strongly recommend that the operator read this manual and thoroughly understand the operational instructions for the engine and all related accessories before the boat is used.

## **BE RESPONSIBLE FOR SAFER BOATING**

- **ALCOHOL and DRUGS** - The debilitating effects of alcohol and other drugs reduces reaction time and detracts from judgment. The combined effect of the outdoor environment... sun, heat, wind, rough water, and noise can be more fatiguing than one would imagine and, combined with drugs or alcohol, can be very dangerous.
- **GAME PLAN** - Tell a friend, neighbor or another family member where you will be boating and when you plan to return. Be certain that this individual has a good description of your boat and any other identifying information that could be needed to help find you should an emergency arise.
- **TOOLS and SPARE PARTS** - Many people have been stranded by minor breakdowns that they could have repaired themselves. It is a good idea to carry a few tools and common spare parts and to be familiar with simple repairs that you can easily accomplish.
- **GASOLINE RESERVES** - Never push your boating range to the limit of your gas tank capacity... one-third of the fuel to go, one-third to come back and one-third to reserve.
- **GOOD BOAT KEEPING** - A clean boat is a safer boat. Take care to see that rods, lures, nets, gaffs and other potentially harmful gear are properly stowed so that it cannot blow or move around while the boat is underway. Perform all maintenance and safety checks regularly. Secure all icebox or cooler lids and place any trash or debris safely under cover until the trip is over.
- **SPEED and SKILL** - The fast and powerful boat can require the operator to exercise a high level of skill and attention to driving. Only go as fast as your skill and good judgment dictates is safe. You are in charge of the well being of your passengers and yourself. Be alert for any hazards in the water and operate your boat only in such a manner as would be appropriate for the water conditions. Be a good boating "neighbor" and do not create a hazard or annoyance to others. The best safety equipment is your own good judgment.
- **SKIERS and SWIMMERS** - Do not allow operation of the engine when anyone is in the water near the stern of the boat. Never back up to a down skier or anyone in the water. Never drive your boat directly behind a skier.

## **CARBON MONOXIDE**

Carbon monoxide is a deadly gas that is odorless, tasteless and colorless. It is present in the exhaust of internal combustion engines. Inhaling sufficient concentrations of carbon monoxide can be fatal within minutes. Early signs of carbon monoxide poisoning may include headache, nausea, fatigue, drowsiness, confusion and vomiting. **DO NOT MISTAKE THESE SYMPTOMS FOR SEASICKNESS.** If any of these symptoms occur to you or any of your passengers, ventilate the boat by opening the side curtains or forward hatch to remove the fumes and immediately seek medical attention.

Carbon monoxide can be drawn into the cockpit area over the stern of the boat. When operating the engine, ventilate the cockpit area by removing side curtains or opening forward hatches to allow fresh air to flow through. Do not operate the engine if your boat is moored in a confined area.

 **WARNING** Exhaust from a running engine can cause an accumulation of carbon monoxide gas in the cockpit area when the canvas top and side curtains are installed. Provide adequate ventilation when these coverings are installed in their closed positions.

## TABLE OF CONTENTS

Getting to Know and Handle Your Ranger Boat .....	2
Be Responsible for Safer Boating .....	6
Carbon Monoxide Warning .....	7
Special Information .....	9
Your Ranger Dealer's Responsibilities.....	10
Owner/Operator's Responsibilities.....	10
Warning and Cautions .....	11
Hazard Labeling .....	12 & 13
Hull Identification Plate .....	14
U.S. Coast Guard Capacity Information Plate .....	15
Recommended On-Plane Seating Locations.....	16
Fuel System .....	17
Your Livewell Aeration System.....	18
Steering at Console .....	24
Your Boat's Finish .....	29
Maintenance and Repair .....	29
Your Power Pedestals .....	32
Key Locks, Carpet, and Upholstery .....	34
Cleaning Marine Vinyl .....	35 & 36
Adding Accessories To Your Boat .....	37
Wiring Diagrams .....	39
Electrical System .....	46
Fuse Panel Information .....	46
Keyless Ignition .....	51
Saltwater Series .....	52
Installation of Trolling Motor Plug.....	53
Installation of Battery Charger Plug .....	54
Federal Requirements for Recreational Boats.....	56
Boat Data (Owner's Information) .....	58

## YOUR RANGER TRAIL® TRAILER

General Information and Maintenance .....	59
E-Z Lube Hubs and Cool Hubs .....	60
Trailer Brakes .....	61
DB-42 Disc Brake Parts List .....	64
Removable Tongue .....	66
Swing Hitch .....	67
Before Towing Your Ranger Trail Trailer .....	67
Towing Your Ranger Trail Trailer .....	67
Ranger Trail Parts List .....	69 & 72
Trailer Exploded View .....	70 & 71
Limited Warranty .....	73





## **SPECIAL INFORMATION**

The following special information is intended to alert you to possible dangers and to information important to the safe operation of your boat and other equipment. Observe them carefully. However, simply being aware of the “WARNING”, “CAUTION” AND “NOTICE” notations in this manual will not eliminate the dangers that they signal if you do not implement the information. These warnings, plus common sense operation will insure you a safe and fun boating or fishing outing.

Please take special note when you see one of the following signs:

 **WARNING** Failure to follow the advice of a “WARNING” may result in bodily injury or death.

 **CAUTION** Non-compliance with “CAUTION” instructions could result in failure of, or damage to, the product and/or equipment.

 **NOTICE** Draws special attention to installation, operation, or other important maintenance information.

ALL information or instructions in this manual could be necessary for proper operation and/or maintenance. If you do not understand any portion of this manual, please contact your Ranger dealer or our Customer Service Department for any additional information.

### **IMPORTANT: Your Ranger Dealer’s Responsibilities...**

Generally, it is the dealer’s responsibility to the customer to make sure that the boat has been equipped as ordered with a properly installed and functioning engine that is within the horsepower rating specified for that model boat. The dealer should see that the engine is outfitted with the proper propeller for that boat model and for the load that the boat is normally expected to carry.

The dealer should help to familiarize the customer with the onboard equipment and explain operation of this equipment; the engine operation; and the proper functioning and operation of the boat itself.

Prior to delivery, the dealer should make certain that the product and equipment is completely operational; the proper propeller is installed; and that all oil, fuel system and lubrications systems are understood. The dealer should explain the operation of all instrumentation equipment, and the boat electrical and livewell systems.

The dealer should check for correct carburetor adjustment, throttle and steering functioning, and instrumentation accuracy. Engine cooling water should be properly circulating.

The dealer should test for maximum engine RPM as specified in the engine manufacturer's specification sheet(s) and/or engine owner's manual for proper operation of all equipment and for proper adjustment of steering effort and direction. All necessary adjustments for maximum efficiency should be made.

### **Owner/Operator's Responsibilities...**

It is the owner/operator's responsibility to perform all safety checks and to ensure that all lubrication and maintenance instructions are complied with for maximum safety and proper operation.

It is also the owner/operator's responsibility to return the unit to the Ranger dealer for a periodic checkup.

The owner/operator is responsible for the correct operation of the boat and for the safety of its occupants. Be sure that all operators read this manual before attempting to operate the boat. Your passengers should be shown the location and use of all emergency equipment and one passenger should be instructed how to handle the boat in case of emergency. U.S. Coast Guard requirements for PFDs (Personal Flotation Devices, or Life vests) can vary, depending on the type of boat. Be sure to comply with the U.S. Coast Guard regulations that apply to your boat. The owner/operator should, however, make certain that all passengers in the boat are in possession of, and are securely wearing a PFD whenever the boat is in operation. We strongly recommend that an engine emergency stop switch be securely connected to the boat operator any time that the engine is in operation!

Learn the waterway rules of the locality in which you intend to operate your boat. Navigable waterways are controlled by Federal regulations while inland lakes and Canadian waters are controlled by local jurisdictions. Obey all regulations to protect yourself, your passengers, and fellow boating enthusiasts.

Before boating, obtain the weather forecast for your area. Familiarize yourself with the weather bureau warning system signal(s) and waterway traffic sign/markings information.

Contact your local U.S. Coast Guard Auxiliary and take advantage of their excellent boating and safety classes and seasonal boat inspections.

**! WARNING** Operating a boat with an engine of horsepower in excess of that specified on the boat's capacity plate can result in loss of control over the boat's operation and could lead to an accident resulting in injury or death of the boat's occupants.









**! WARNING** Imprudent operation of the boat, with or without the use of PFDs and an approved engine emergency stop switch, can lead to property damage, injury or death of the boat operator or passenger(s), or other, whether within the boat or outside the boat.



**! WARNING** The boat operator should insure that the lanyard connection to the emergency stop switch is of ample length to insure that the inadvertent activation of the switch is not likely. Accidental triggering of the emergency stop switch could result in loss of engine power at inopportune times, such as while docking or in heavy seas, strong currents or high winds and could lead to an accident resulting in injury or death.

**! WARNING** Do not exceed the maximum weight and persons capacity found on the U.S. Coast Guard capacity information plate located on your boat. Overloading severely affects the stability and handling of your boat and could lead to an accident causing injury or death.

## HAZARD LABELING

The hazard warning decals shown on the following pages may be found in various locations on your boat and trailer (photos are not necessarily to scale). Some labels are not appropriate for every boat/trailer model so your rig may not have them all. Check with your Ranger dealer to find out what labels your boat and trailer should have and ask them to order any necessary replacements.

 <p><b>WARNING</b></p> <p>Rotating propeller can cause serious injury or death. Never approach or use ladder when motor is running.</p>	 <p><b>WARNING</b></p> <p>Install ski pylon securely before use. Insert pin thru receiver and ski tow pylon. Pushing pylon into mounting hole until red line is no longer visible. Install pin thru receiver and pylon to secure position. Failure to secure pylon may result in possible injury or death.</p>
 <p><b>WARNING</b></p> <p>Rotating propeller can cause serious injury or death. Shut off motor when near persons in water.</p>	 <p><b>WARNING</b></p>  <p>Avoid serious injury or death from fire or explosion, resulting from leaking fuel. Inspect system for leaks at least once a year.</p>
 <p><b>WARNING</b></p> <p>High speed turns may cause loss of boat control. Avoid serious injury or death. Reduce speed before attempting turns. Read owner's manual for more information..</p>	 <p><b>WARNING</b></p> <p>Avoid serious injury or death from fire, explosion or electrical shock.</p> <ul style="list-style-type: none"> <li>• Ensure power is turned off before connecting to an AC source.</li> <li>• Make connection in an open atmosphere free of explosive fumes.</li> <li>• Make connection in a secure manner that will avoid contact with the water.</li> </ul> 
 <p><b>WARNING</b></p> <p>Fuel vapors are a fire and explosion hazard. To avoid injury or death, do not store fuel or flammable liquids here.</p>	<p align="center"><b>▲ WARNING ▲</b></p> <p><b>EXHAUST FUMES FROM ENGINE CONTAIN DEADLY CARBON MONOXIDE GAS. BOATS WITH CANVAS OR POOR VENTILATION ARE MOST LIKELY TO COLLECT FUMES. SICKNESS SYMPTOMS INCLUDE HEADACHE, NAUSEA AND DIZZINESS. DO NOT MISTAKE FOR SEASICKNESS. VENTILATE BOAT. OPEN SIDE CURTAINS OR FORWARD HATCHES TO REMOVE FUMES.</b></p>

<b>! WARNING</b>		
	<b>Avoid serious or fatal injury. Do not occupy seat when speed exceeds 5 MPH. Avoid injuries from dislodged seat. Secure unoccupied seat.</b>	
<b>B</b>	<b>Designed Application Class B</b>	<b>B</b>
 The Springfield Marine Company 1093 Cynthia St. • PO Box 588 • Nixa, MO 65714		

<b>! WARNING</b>
<p>1. You will not be able to stop the tow vehicle and trailer as quickly as you can stop the tow vehicle alone. <b>ANTICIPATE STOPS, BRAKE EARLY.</b> Allow additional distance for stopping.</p> <p>2. Check lug nuts and tire pressure each trip. Make sure that lug nuts are in place and tight! Maintain tire pressure at 50 psi for proper load carrying and to avoid irregular wear!</p>

<b>WARNING</b>
<b>50 PSI</b>
TIRE PRESSURE MUST BE MAINTAINED FOR PROPER LOAD CARRYING AND TO AVOID IRREGULAR WEAR!

<b>WARNING</b> BEFORE TOWING <b>ALWAYS</b> INSTALL A PIN OR LOCK INTO COUPLER TO ENSURE THAT LATCH CANNOT OPEN AND COUPLER CANNOT COME OFF BALL.
--

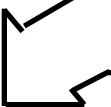
 <b>BEFORE USE, PUSH UP ON TAB TO ASSURE BRAKES ARE RELEASED.</b>
---

## HULL IDENTIFICATION PLATE

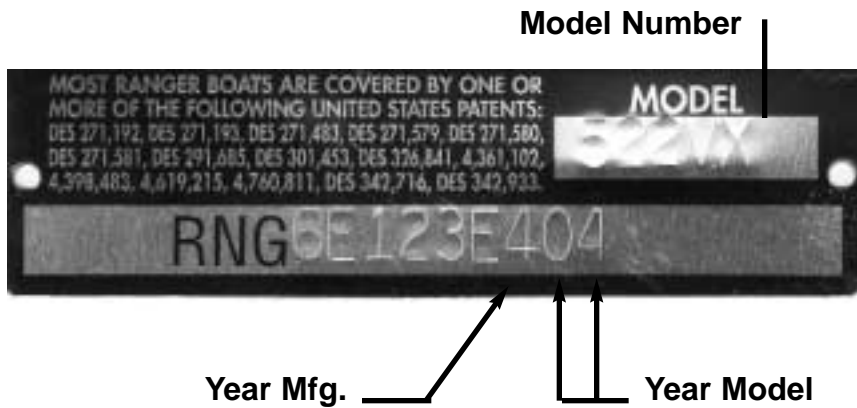

The hull I.D. Plate is located on the outboard side of the starboard transom, above the water line, and contains the following information:

- (1) Boat patent information
- (2) Model Number - This number should be referred to when ordering parts or making other inquiries.
- (3) Hull Identification Number (Serial Number) - Should also be included in any inquiries or when ordering parts. The U.S.C.G. requires the H.I.N. number be permanently affixed and remain on the starboard transom of the boat. Do not alter this plate in any way.

## U.S. COAST GUARD CAPACITY INFORMATION PLATE



Familiarize yourself with your boat's maximum capacities. Do not exceed the maximum weight (in pounds) or persons capacity (number) found on the U.S.C.G. capacity information plate attached to your boat. **Know the ratings and load your boat accordingly. It is a must for safe boating.**

**⚠ WARNING** Failure to observe maximum weight and horsepower capacities could create conditions favorable to an accident that could result in injury or death to the occupants.

## RECOMMENDED ON-PLANE SEATING LOCATIONS

A decal similar to the one in Fig. 1, below, should be found on your boat in the area of the U.S. Coast Guard Capacity plate. The areas marked by "X's" are the areas of the boat considered safe and suitable for on-plane seating. The operator of the boat should be familiar with these locations. The boat should not be operated at or above planing speeds with persons on board not seated in the designated areas shown.

FIG. 1

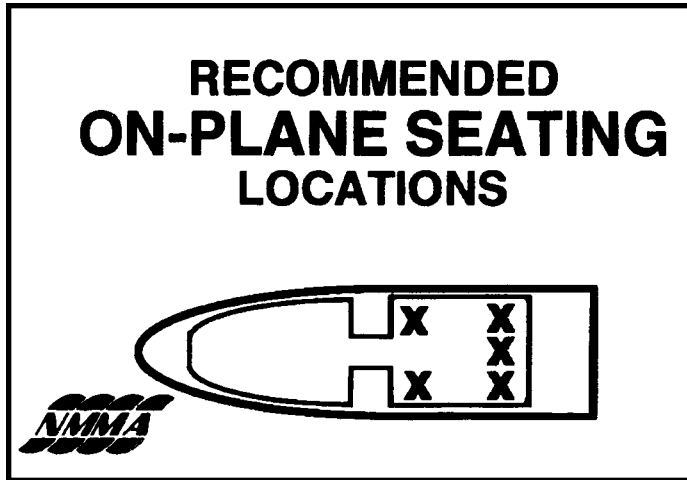

**⚠ WARNING** Do not operate the boat on plane with persons located outside the on-plane locations shown on the decal. Failure to do so could cause a person(s) to be thrown overboard resulting in injury or death.



## FUEL SYSTEM

The fuel system consists of a fuel tank equipped with an electric sending unit. The fuel level is displayed on the console mounted gauge when the ignition switch is "on". On models with two tanks, a console mounted switch marked with a fuel pump symbol or just "fuel", is used to switch the gauge from one tank to the other. Push the fuel pump symbol switch to display the level in tank 1 (starboard) or tank 2 (port). Or, on some models, push the switch to the left to display the port tank fuel level and push to the right to display the starboard tank fuel level. The center position is "off". A fuel hose connects the fuel tank to the engine. On models with more than one tank, a switch valve is installed to switch from tank to tank. This valve, located at the driver seat, on the panel supporting the driver and passenger seat or near the splashwell, depending on the model, is clearly marked and easily operated. Some models have a manual fuel shutoff valve located in the pick up tube at the fuel tank. Contact your Ranger dealer for information on proper fuel shutoff valve access.

### SAFETY AND MAINTENANCE TIPS

The fuel system in your Ranger requires little or no maintenance. However, the periodic inspection outlined below is strongly recommended. Contact your Ranger dealer for proper fuel tank access for your model.

- (1) Check fuel tank(s) for leakage, especially around electric sender and fuel hose connections.
- (2) Check fuel tank hold down brackets, making sure they are secure.
- (3) Check battery hold down or boxes, making sure they are secure.
- (4) Do not store items on, in, or around fuel tanks or batteries. "Good housekeeping" in this compartment is essential to safe boating and a maintenance-free fuel and electrical system.
- (5) Check hose connections at the deck fuel fill, fuel tank vent, and (if equipped with more than one tank), the fuel switch valve.



### CAUTION

Maintenance or repairs should be performed by your Ranger dealer or other qualified personnel.



### WARNING

Avoid serious injury or death from fire or explosion resulting from leaking fuel. Inspect system for leaks at least once a year.



### WARNING

Fuel vapors are a fire and explosion hazard. Do not store fuel or flammable liquids in boat. Ventilation has not been provided.

Naturally, a leak-free fuel system is a MUST for proper engine operation and on-board safety. Always inspect for fuel leaks prior to connecting battery charger to your engine cranking battery. Rear battery compartment lid should always be open for ventilation when charging the batteries.

## YOUR LIVEWELL AERATION SYSTEM

The livewell aerator system in a Ranger boat is designed to supply the water and oxygen necessary to the survival of your catch. This patented system not only allows fresh water to be pumped in through the aerator supply line(s), but also permits recirculation and aeration at any speed of boat operation.

The recirc position (with aerator running) will only recirculate what water is in the well. It does not bring in any fresh water. This position provides a more positive seal and is good to use if you are going to transport live fish in the well.

The auto position also holds the water in the well and in conjunction with the aerator will allow a mix of fresh water intake and recirculate existing water. This would be the normal position for a day of fishing. The empty position is just that, to empty the water from the well.

On VS models, the livewell aerator timer located on the driver's console, controls the off time of the aerators when the pump switch is in the automatic position. The timer starts and stops the pump at intervals determined by the setting on the timer. Full counterclockwise is minimum off time and full clockwise is maximum off time. To have the aerator pumps run continuously, set the pump switch to the manual position.

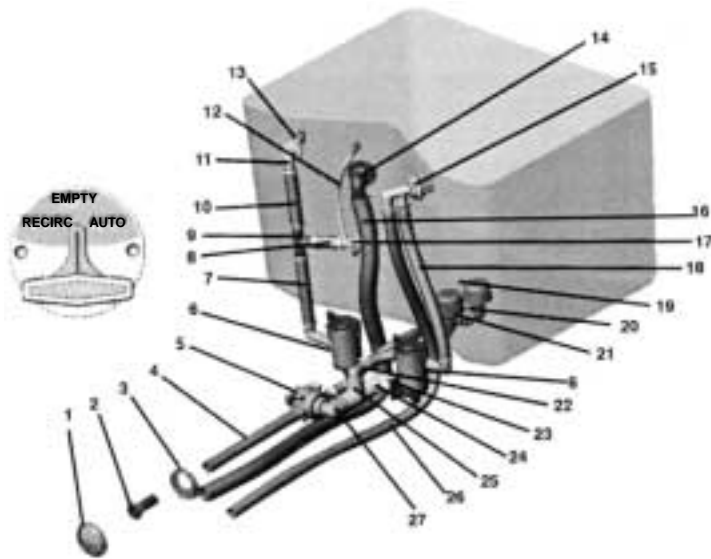

## LIVEWELL PUMP-OUT

Your new Ranger may be equipped with a livewell pump-out system. To use this pump out feature, put the livewell control valve in the recirc position and pull out on the aerator spray head. Turn on the aerator and the water in the well will be emptied. To fill the livewell and resume normal operation, push the aerator spray head in and set the livewell valve to the auto position.

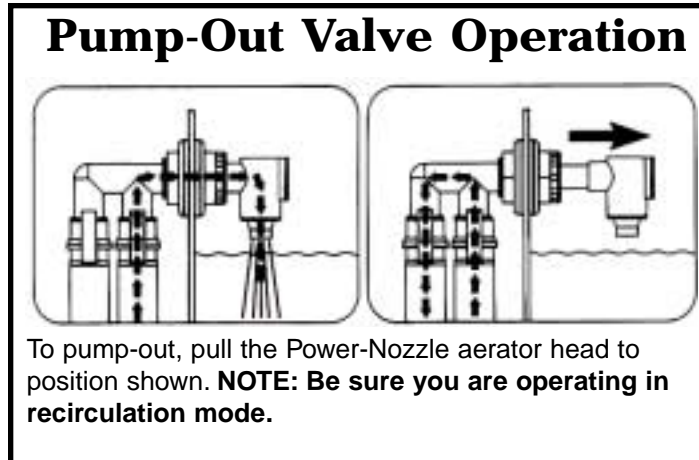

**LIVE WELL PLUMBING ASSEMBLY**

<b>ITEM NUMBER</b>	<b>PART NUMBER</b>	<b>DESCRIPTION</b>
1	7100112	Grommet
2	7100118	Transom Mount Livewell Screen (2pc)
3	7400262	3/4" Blk Spiral Reinf. Water Hose
4	5903070	Aerator Valve Center Empty
5	6000057	750 GPH Aerator Pump
6	7400259	3/4" Hose
7	9831203	3/4" Toe (016-007)
8	7415775	Aerator Spray Head
9	7415855	Venturi Air Aeration Sys Kit
10	7100125	Blk 90 degree 1-1/8" Elbow w/nut
11	6000050	Livewell Pumpout/Sprayhead
12	7400225	1-1/8" Blk Spiral Bldg. Hose
13	7415855	Venturi Air Aeration Sys Kit
14	7100130	Filter Screen
15	7415816	3/4" Male NPT x Male GHT Elbow
16	7415915	3/4" Swivel Female Insert
17	7415766	PVC 3/4" TEE
18	7415838	3/4" 90 degree Elbow
19	7415746	3/4" x 3/4" MPT to Slip Adapter
20	7415928	3/4" x 3/4" x 3/4" TEE (042-007)
21	7400262	3/4" Blk Spiral Reinf. Water Hose
22	7415904	PVC 3/4" TXS 90 degree STR Elbow

## **SALTWATER RECIRCULATING BAITWELL PLUMBING SYSTEM** 2180, 2300 BAY RANGERS AND 223, 191 CAYMANS

### Operation Instructions:

#### Your Livewell Aeration System

1. Fill Baitwell/Continuous Exchange of Water
  - Open valve (A) leaving valve (B) closed
  - Turn pump on
  - Tank will fill until water reaches the overflow
  - Leave pump on for continuous exchange of water



2. Re-circulate Baitwell Water
  - Close valve (A) open valve (B)
  - Turn pump on
  - Water in baitwell will re-circulate

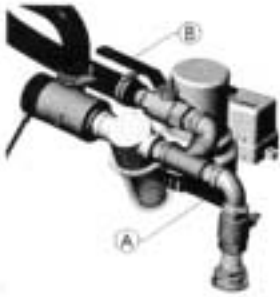

3. Drain Baitwell
  - Turn pump off
  - Open valve (A) and valve (B)



4. Close valve (A) when system is not in use.

## **SALTWATER RECIRCULATING BAITWELL PLUMBING SYSTEM**

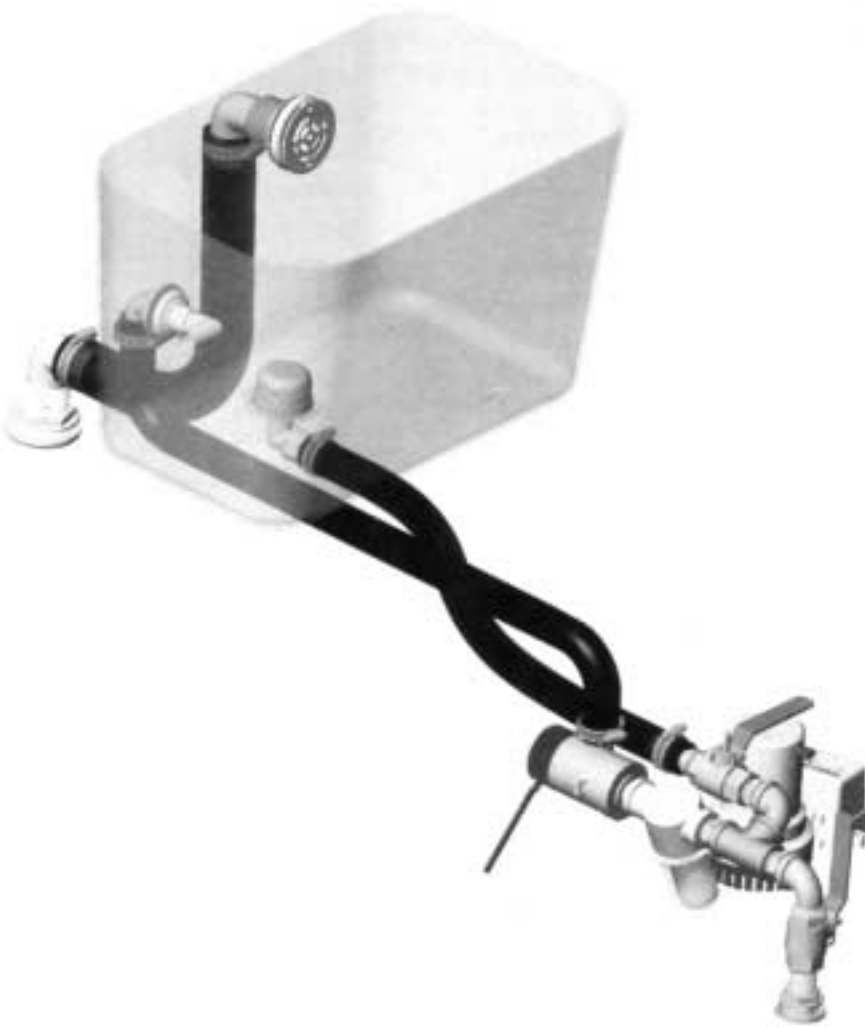

## **MAINTENANCE TIPS FOR AERATOR SYSTEM**

- (1) Remove screens only for flushing aerator system.
- (2) Keep screens in place for cleaning and during operation. Replace damaged or broken screens immediately.
- (3) Do not exceed the recommended fuse size on the aerator pumps (a larger fuse WILL NOT make a stronger aerator system!).
- (4) Lubricate pivot on livewell control cable periodically using light weight machine oil.
- (5) Continual operation of pump (especially dry) will damage pump. Be sure aerator switches are “off” when storing, etc.

## **TROUBLESHOOTING**

### **■ Pump runs, but will not pump water:**

- ⇒ Entrapped air pocket around pump impeller has “air locked” pump. With valve in “fill” position, back boat up slowly to expel entrapped water.
- ⇒ Grass, sticks, or other debris have clogged the filters or cavity around the pump impeller, restricting water flow to pump. Clean screens, or remove screens and flush system with garden hose using moderate pressure.

### **■ Pump will not run (no “hum” is heard):**

- ⇒ Make sure switch is in the “Manual” position (in “Automatic” the pump could be working, but in off time).
- ⇒ Check master breaker switch in the rear compartment.
- ⇒ Check fuse. Replace if necessary.
- ⇒ Check wire connector at pump.
- ⇒ Replace pump.

### **■ Livewells will not hold water in “Fill” position.**

- ⇒ Flush system to clear debris from livewell valve.
- ⇒ Check cable to valve connection for proper adjustment.
- ⇒ Remove cable, put water in livewell to see if well will hold water with cable removed. If so, adjust cable to match actuator arm.
- ⇒ Remove valve and disassemble. Clean inside of valve with warm soapy water and inspect flappers for nicks, cuts and abrasions. Replace flappers if necessary.

## STEERING AT CONSOLE

**⚠ WARNING** The steering in your boat is one of the most important items and should be checked by the driver every time the boat is used. You should school yourself and make it a habit to check the steering methodically. Loose or worn steering could lead to an accident causing injury or death.

Your new Ranger may be equipped with Teleflex Sea Star Pro hydraulic steering.

This system is designed to help reduce engine torque felt at the wheel (see Fig. 3), while providing excellent steering response. However, this is not to be interpreted in any way as an “Automatic Pilot”. A firm grip on the wheel is required at all times. Read the steering owner/installation manual for maintenance instructions.

**⚠ NOTICE** Due to the special valving in the hydraulic helm the steering wheel may not be in the same position each time the steering is returned to center. This is normal operation and should be no cause for alarm.

Other Ranger models may be equipped with no feed back steering. This is mechanical steering that is designed to help reduce engine torque, felt at the wheel, to a minimum. However, a firm grip on the steering wheel is required at all times.

You should familiarize yourself with the feel of the steering at various speeds and trim settings. **NEVER** exceed speeds beyond your comfort level.

**⚠ WARNING** The driver must always keep a firm grip on the steering wheel. Failure to do so could lead to an accident causing injury or death.



### SEA STAR OUTBOARD HYDRAULIC STEERING

Remove, clean and grease the support tube annually with quality marine grease.

Check the steering fluid level in the helm. It should be maintained at no less than 1/2" and no more than 1/8" below the bottom of the filler cap threads. Be careful not to overfill.

Replace any hoses showing signs of wear and remove the cause or re-route hoses.

Check fittings and seal locations for leaks/damage and service as necessary.

If you have installed a jack plate, make sure that there isn't any interference between the jack plate and your steering cylinder. If there is interference, it may occur during full tilt. Lift restrictors or a Tilt Stop Switch should be installed. Please consult your engine manufacturer.

**⚠ WARNING** Failure to comply with maintenance checks may result in loss of steering, causing property damage and/or personal injury. Maintenance requirements will vary depending on usage and climate. Bi-annual inspection by a qualified marine mechanic is required.

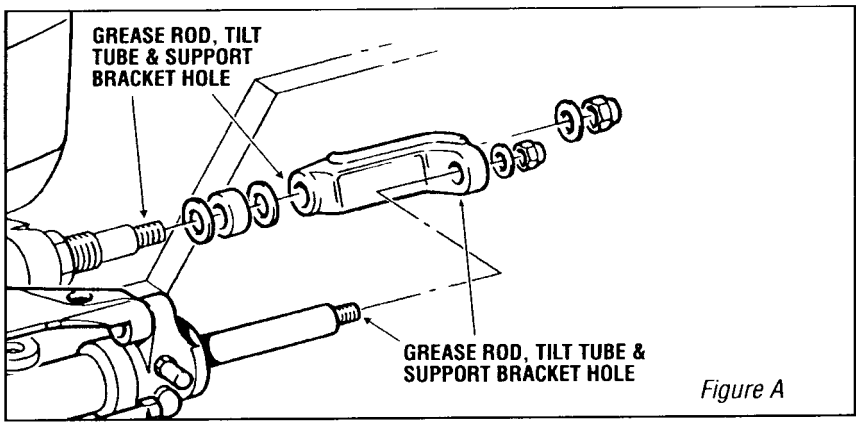

**⚠ CAUTION** Grease rod, tilt tube and support bracket holes once a year.

For complete installation and troubleshooting information, please refer to your SeaStar installation instructions, Book 1.1 (Part # 296784).

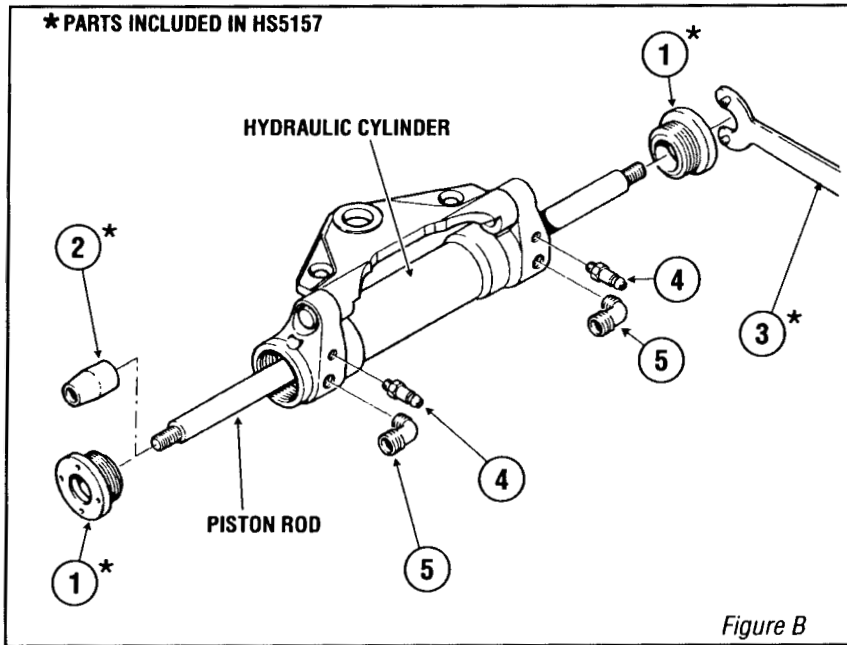

**SEAL REPLACEMENT KIT (PART # HS5157) FOR:  
FRONT MOUNT CYLINDER (PART # HC5345)**

<b>Item</b>	<b>Part #</b>	<b>Quantity</b>	<b>Description</b>
1	797021	2	Seal Gland Only
2	745920	1	Seal Gland Assembly Guide Tool
3	745525	1	Pin Wrench Only
4	828980	1	Bleeder Fitting
5	600601	1	Elbow Fitting

**SEAL KIT # HS5157**

1	797021	2	Seal Gland Only
2	745920	1	Seal Gland Assembly Guide Tool
3	745525	1	Pin Wrench Only

FIG. 3

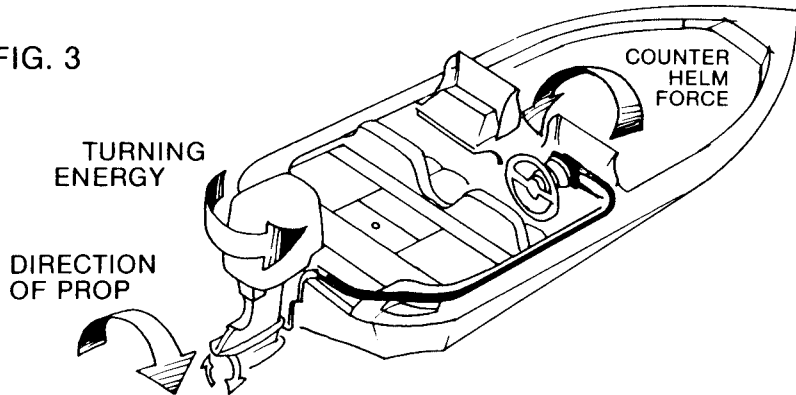

### STEERING CONNECTIONS AT ENGINE

The steering may be connected at the engine by a method similar to the ones shown in Figures 4 & 5 ( page 28).

Because Ranger does not supply the “cable to engine” connectors, except on pre-rigged packages, we will not make specific installation or torque recommendations. However, Figures 4 & 5 show maintenance and check points that should be regularly inspected.

**⚠ CAUTION** See your authorized marine dealer for specific information concerning maintenance of engine connections.

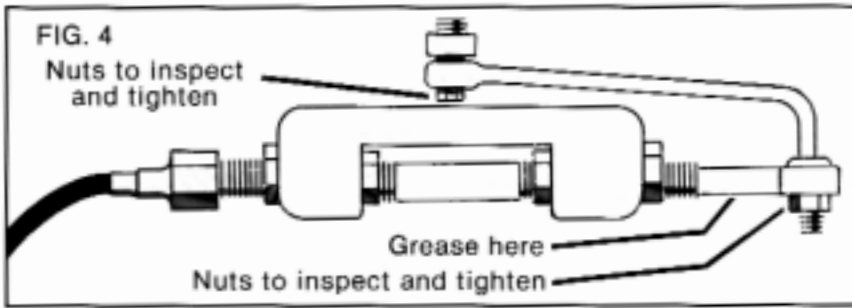

**▲ CAUTION** See engine owner's manual for proper greasing and maintenance of engine link rod and steering kit.

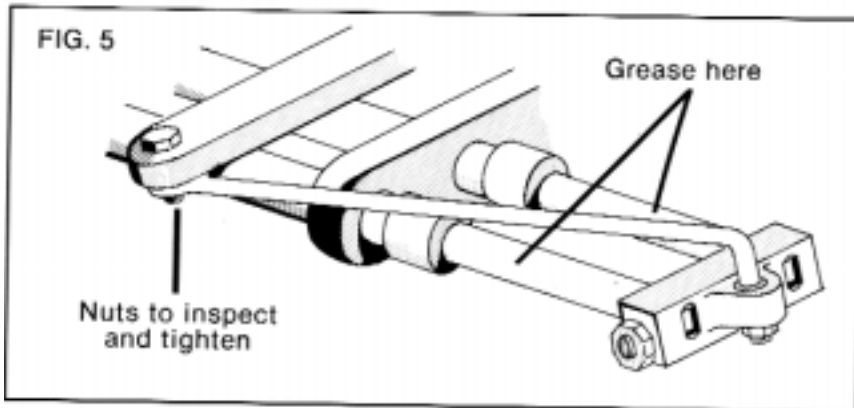

## **YOUR BOAT'S FINISH... MAINTENANCE AND REPAIR**

The gel-coat (color) used on your Ranger® Boat is of the highest quality available today. To keep it looking new and in good condition these tips will prove helpful.

- A light duty rubbing compound (available at most auto parts stores) is recommended for stains such as mold, water lines on the hull, fine scratches on finish or just to bring back that “look new” shine.
- Automotive wax or polish is good for preserving the shine and building an “armor coat” to prevent scratches and will also help protect hull while in wet storage.
- A boat cover (which is available from your Ranger dealer) is also a wise investment to help prevent damage while the boat is at home or on the road.



### **NOTICE**

Do not use acids or other strong chemicals to clean your boat.

Careful as you may be, you will get that scratch from the dock or beach that will need some attention. Most Ranger dealers are equipped to do fiberglass repair, and large jobs are better left to the experts. However, minor scratches, chips, and gouges may be repaired by you. These instructions are to repair solid color gel-coat only, not poliflake:

1. Using masking tape, tape around damaged area slightly larger than actual flaw, keeping area to be repaired as small as possible.
2. Remove any damaged glass or gel-coat. Sand damaged area and all surface inside tape, enough to rough up area and remove shine, using #220 grit dry sand paper.

3. Wash area with a solvent such as acetone and allow to dry.

**⚠ WARNING** These materials are very flammable. Do not smoke or use electric equipment while using them. Improper handling could result in an explosion resulting in injury or death.

4. Using Ranger touch-up gel-coat or putty only, thoroughly mix 1% catalyst (MEKP) with desired amount of gel-coat or putty.

**⚠ NOTICE** Gel-coat will not cure by itself. You must use a catalyst.

5. With a putty knife, trowel catalyzed gel-coat in desired area, leaving it slightly higher than the original surface to allow for shrinkage.
6. When patch has dried, remove masking tape and carefully sand back to the original shape using #600 grit WET sandpaper. Then buff with a light duty buffing compound.

NOTE: Area may have to be filled more than once due to shrinkage.

NOTE: Due to different dye lots the color may vary somewhat. However, we take all the steps to keep our color consistent.

**⚠ NOTICE** Do not hold buffer in one area long enough to burn gel-coat.

**⚠ NOTICE** Do not sand metalflake surfaces. A different procedure is used to repair these finishes. You should contact your Ranger dealer for more information.

**⚠ NOTICE** Gel-coat will not cure by itself. You must use a catalyst.

## **YOUR POWER PEDESTALS**

A “power pedestal” is a nitrogen gas filled steel cylinder that is used to raise and lower the fishing seats mounted on the forward and aft casting platforms. This enables you to select the proper seat height for comfort in any fishing situation. Pushing the empty seats all the way down helps to provide an unobstructed viewing area around the boat when underway.

To raise the seat, simply lift your weight slightly off the seat while raising the seat actuating lever simultaneously. To lower the seat, keep your weight on the seat and lift the lever up.

These pedestals are constructed to the highest standard of workmanship and will give years of trouble-free service. A minimum amount of care will insure proper operation. Periodically apply a light weight oil (like household “3 -in-1” oil) to the power unit piston. Take care not to over stress the pedestal by placing excessive strain on the seat and power unit while it is extended into the full up position. Always lower the seat to the full down position when the boat is underway. We recommend that the seat and pedestal be removed from the front casting deck and remounted into the special base mounted in the front of the deck floor when running. Should your boat not have the additional base, the front fishing seat should be removed and securely placed in the floor of the boat.

Your power pedestals are warranted for three years against defects in materials and workmanship. Should a pedestal fail, return the unit to Springfield Marine, Attention: Warranty/Repair, Hwy. 160, P.O. Box 588, Nixa, Missouri 65714, or call 417-725-2667. Repairs not covered by warranty will be charged at their regular rate.

 **WARNING** Power unit is under pressure. Do not attempt to disassemble it or tamper with it in any way. Improper handling could result in severe injury or death.

If your power pedestal will not remain in position, either up or down, you may need to make a minor adjustment to the air cylinder that causes the pedestal to be raised up and down.

With your chair removed from the pedestal, use a Phillips #0 screwdriver to move the adjustment screw as shown in the accompanying diagram.



If your seat will not raise up to the proper height, adjust the screw approximately 1/4 (one-quarter) turn in a counter-clockwise direction and try the pedestal again.

If your seat will not remain in the upright position, move the adjustment screw approximately 1/4 (one-quarter) turn in a clockwise direction.

NOTE: You may need to fine-tune your pedestal by moving the adjustment screw a bit more in one direction or the other.

**NON-ADJUSTABLE  
SNAP LOCK SWIVEL**

Adjust the screw in  
the end of the air  
cylinder as needed

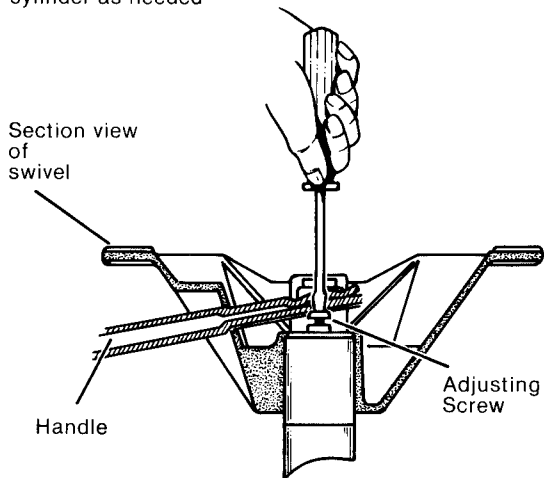

**ADJUSTING AIR RIDE HANDLE  
Prior To Installing Seat**

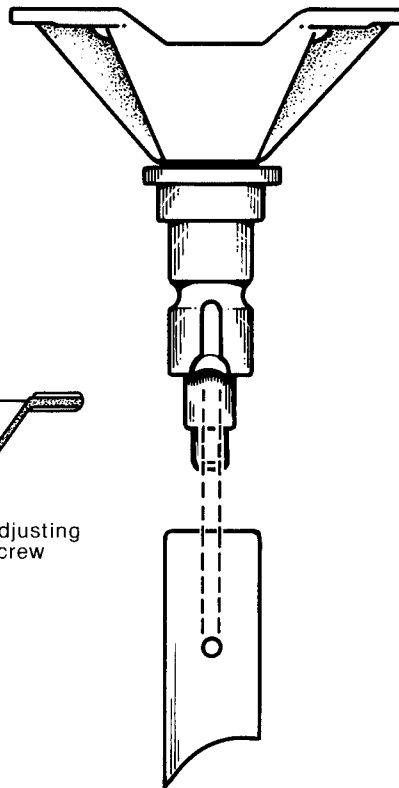

\* Non-Adjustable pedestals are standard on some models, the same warranty applies.

## KEY LOCKS, CARPET AND UPHOLSTERY

Your Ranger® boat has been equipped with top-quality marine grade key locks to secure your storage areas. Should your boat be subjected to use in or near salt water, care should be taken to flush the locks out thoroughly with fresh water to prevent corrosion.

The carpet in your boat is the finest grade available. Although the special backing is RESISTANT to oil and gasoline, spills should be removed with soap and water to maintain the good looks and extend the carpet life. A car-wash is suitable for washing and rinsing your carpet as well as cleaning the fiberglass surfaces.

**⚠ NOTICE** The popular and effective “fish scents” that are commonly sprayed on lures today will cause deterioration of the carpet backing. Use caution to spray these formulas well away from your boat carpet! Any spills should be cleaned up promptly.

Your Ranger upholstery is top-grade marine vinyl. Naturally, the suppleness and color fidelity of the upholstery is best maintained by storing your boat out of direct sunlight. Cleaning and conditioning of your upholstery is best accomplished with an approved, top-quality vinyl cleaner. To loosen stubborn soil or embedded dirt in textured surfaces, use a soft bristle brush, your approved cleanser, followed by wiping with a damp sponge. See specific suggestions for cleaning of marine vinyl on pages 35 and 36.

**⚠ WARNING** Do not use acetone, paint remover or other strong solvents on boat's upholstery.

## CLEANING MARINE VINYL

For general purpose cleaning, use Vinyl Finish Vinyl Cleaner, Fantastik, or warm water with a mild dish soap such as Dawn or Ivory. Gently scrub with a small soft bristle brush.

For dirt build-up, use Vinyl Finish Vinyl Cleaners. Let soak for approximately 10 minutes, then gently scrub with a soft bristle brush. For specific stain removal, refer to the chart on page 36 or the staining agent's stain removal instructions.

<p><b>⚠ CAUTION</b> DO NOT use Formula 409 (the bottle states the product should not be used on vinyl.)</p> <p><b>DO NOT</b> use kerosene, gasoline, or acetone, as they will remove the protective marine top coat on your vinyl.</p> <p><b>DO NOT</b> use any silicone based protectants. They will extract the plasticizers, leaving the vinyl hard and brittle, and eventually cracking will occur.</p>
---

### USE

Vinyl Finish Vinyl Cleaner  
Dish Soap (Dawn, Ivory)  
Fantastik  
303 Protectant

### DO NOT USE

Formula 409  
Murphy's Oil Soap  
Simple Green  
DC Plus  
ArmorAll  
Top Kote Sealant  
Son-of-a-Gun  
Orange 88 Degreaser  
Roll-Off  
Bleach/Baking Soda  
Turtle Wax Tar Remover  
APCO  
Harbor Mate

Certain household cleaners, powdered abrasives, steel wool, and industrial cleansers can cause damage and discoloration and are not recommended.

Dry cleaning fluids and lacquer solvents/acetone (for example, nail polish remover) should not be used as they will remove printed pattern and/or gloss.

Waxes should be used with caution as many contain dyes or solvents that can permanently damage the protective coating.

This chart contains methods for removing common stains and soils:

- A. Medium-soft brush, warm soapy water. Rinse. Dry.
- B. Vinyl Finish Cleaner or household cleaner such as Fantastik.
- C. One tablespoon ammonia, one-fourth cup hydrogen peroxide, three-fourths cup water applied with medium soft brush. Rinse. Dry.
- D. Wipe or scrape off excess (chill gum with ice first).
- E. Denatured Alcohol. Rinse. Dry.
- F. Follow instructions of stain agent manufacturer.

	<b>STEP 1</b>	<b>STEP 2</b>	<b>STEP 3</b>
Ballpoint Ink*	E	B	A
Chewing Gum	D	B	A
Coffee, Tea, Chocolate	B		
Crayon	D	B	
Grease	D	B	F
Household Soil	A	B	
Ketchup	A	B	
Make Up (Lipstick, eye shadow etc.)	A	B	
Mildew, Wet Leaves*	C	B	A
Motor Oil	B		
Paint, Dried Oil Base	D	B	A
Paint, Fresh Oil Base	D	A	F
Paint, Latex	A	B	F
Permanent Marker*	E	B	C
Shoe Polish*	D	B	F
Spray Paint	B	F	
Suntan Lotion*	A	B	
Tar/Asphalt	D	B	
Yellow Mustard	A	B	C

\* Suntan lotion, tree pollen, wet leaves, and some other products contain dyes that stain permanently.

## **ADDING ACCESSORIES TO YOUR BOAT...**

The bow section of the gunwale is properly reinforced for installing such accessories as trolling motors and depth sounders. We recommend through-bolting all trolling motors, anchor davits and other heavier accessories. Normally 1/4" stainless steel bolts with self locking nuts and 1-1/4" fender washers will do the job. Lightweight depth sounders or similar equipment and hardware can be installed using #8 or #10 stainless steel screws. Always drill a pilot hole through the fiberglass (just smaller than the screw you're going to use) and use a counter sink to chamfer the pilot hole before attempting to install a screw. This lessens the chance of "stripping" the hold or chipping the gel-coat around the hole.

If additional instruments are desired on the console, holes may be drilled using a hole saw of the proper size.



### **NOTICE**

Use Marine Sealer around all screws installed into transom or floor of boat. When installing screws below water line, be sure sealer used is recommended for such.

When installing additional electric accessories, always use the proper gauge (size) wire recommended for that item. Insure that the proper size breaker or fuse is used. "Splicing" into another accessory's power supply could overload the circuit and should be avoided.



### **CAUTION**

Always disconnect the positive and negative leads from the battery terminals before installing, removing, servicing, or troubleshooting any part of the electrical system.

**HOOK UP OF TROLLING MOTOR LEADS:**

4 WIRE	RED to Battery	1 (+)	positive
24 VOLT	BLACK to Battery	1 (-)	negative
SYSTEM	ORANGE to Battery	2 (+)	positive
	WHITE to Battery	2 (-)	negative
2 WIRE	RED to Battery	1 (+)	positive
24 VOLT	BLACK to Battery	2 (-)	negative
SYSTEM	WHITE from Battery	1 (-)	negative
	to Battery	2 (+)	positive
2 WIRE	RED to Battery	1 (+)	positive
12 VOLT	BLACK to Battery	1 (-)	negative
SYSTEM			

**⚠ CAUTION** Hooking up leads to trolling motor in any other manner could result in severe damage to both batteries and panel.

Breakers are circuit protection (50 amp 12 volt) for the positive (+) leads in the trolling motor wiring (bow to stern). A problem in the system could result in the breaker(s) being tripped. Should this occur, the breaker(s) can be reset by pushing the switch. If this occurs again, disconnect battery leads and trace immediately, or take it to your Ranger dealer for repair.

An ignition protected circuit breaker is used for the accessories. Should a breaker trip, simply reset. This switch should also be in the "off" position when trailering or storing the boat. It acts as a master switch and turns off all accessories getting their power from the Ranger fuse panel. Remember, engine circuits will not be affected by these breakers/switches, but could have breakers or fuses of their own. Consult your engine owners manual for electrical particulars.

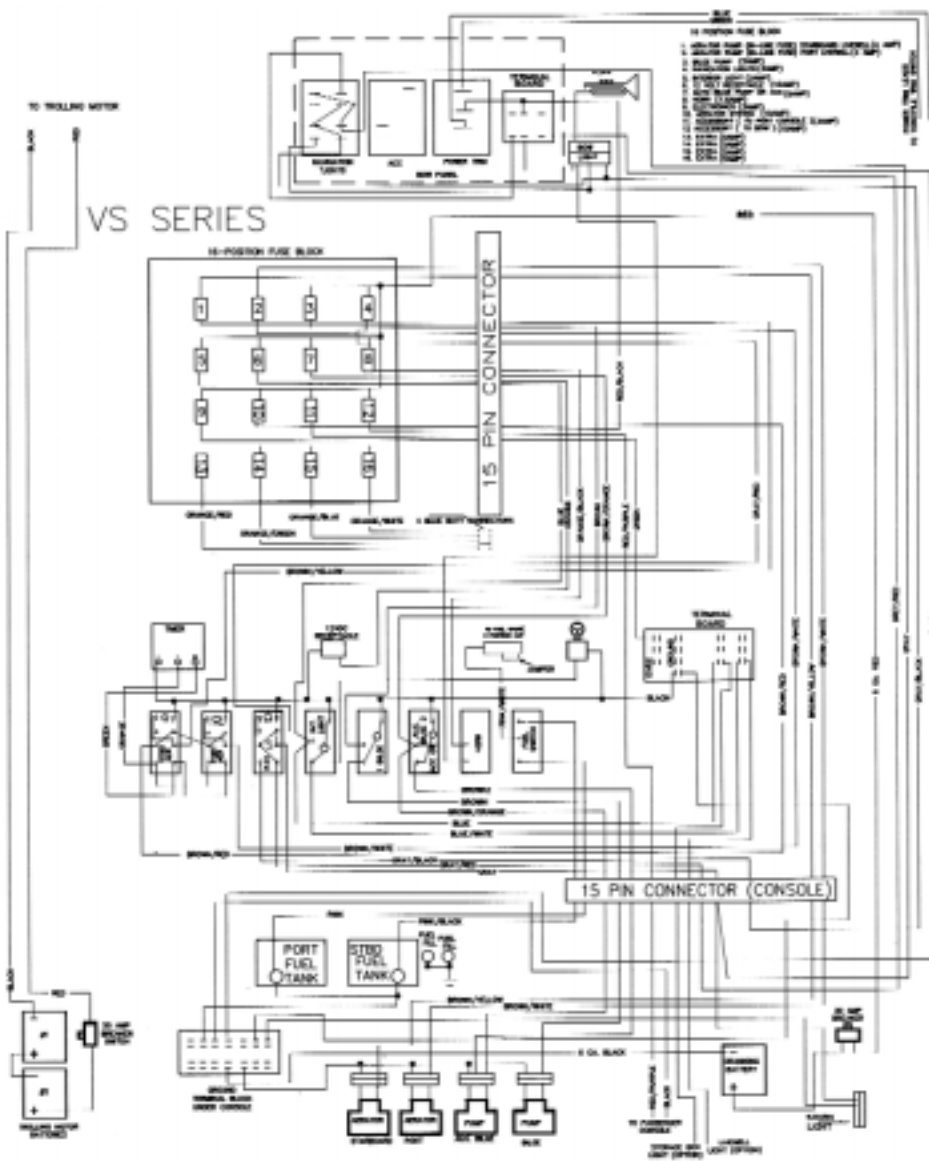

SOME MODELS HAVE ONLY 1 FUEL TANK, IN WHICH CASE THE SENDER WIRE IS PINK AND NO FUEL SWITCH APPEARS ON CONSOLE.

# COMANCHE SERIES





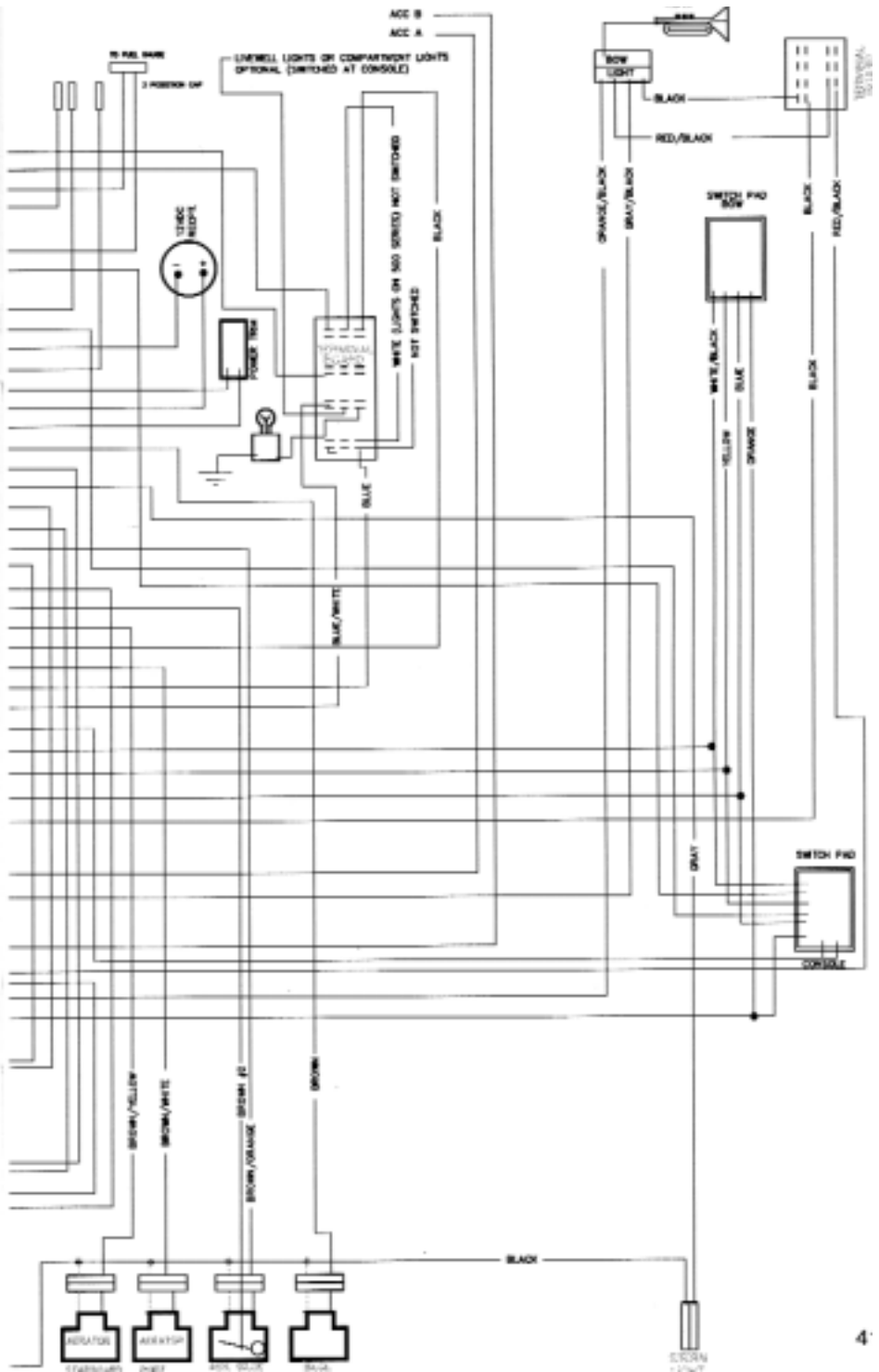

4

# FISHERMAN SERIES

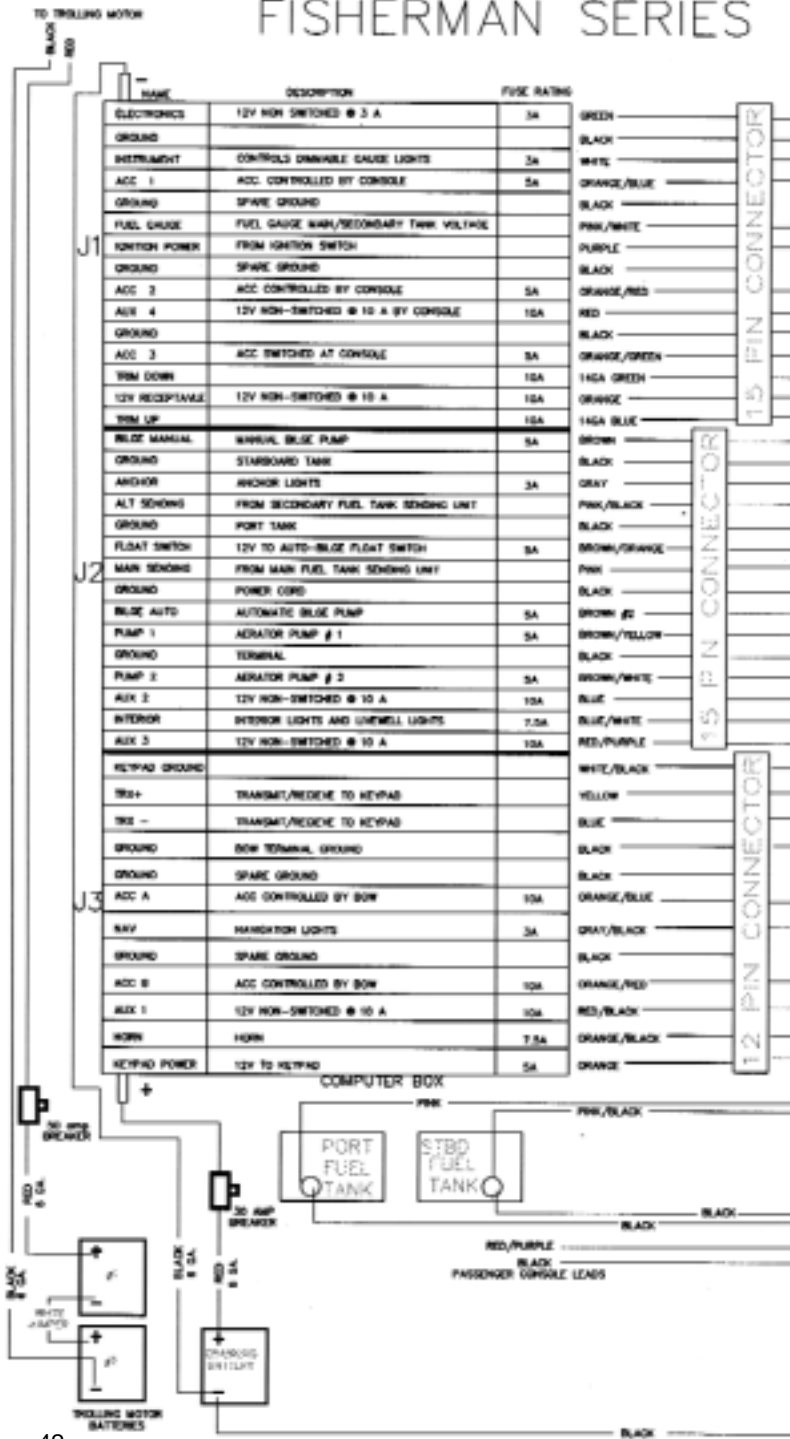

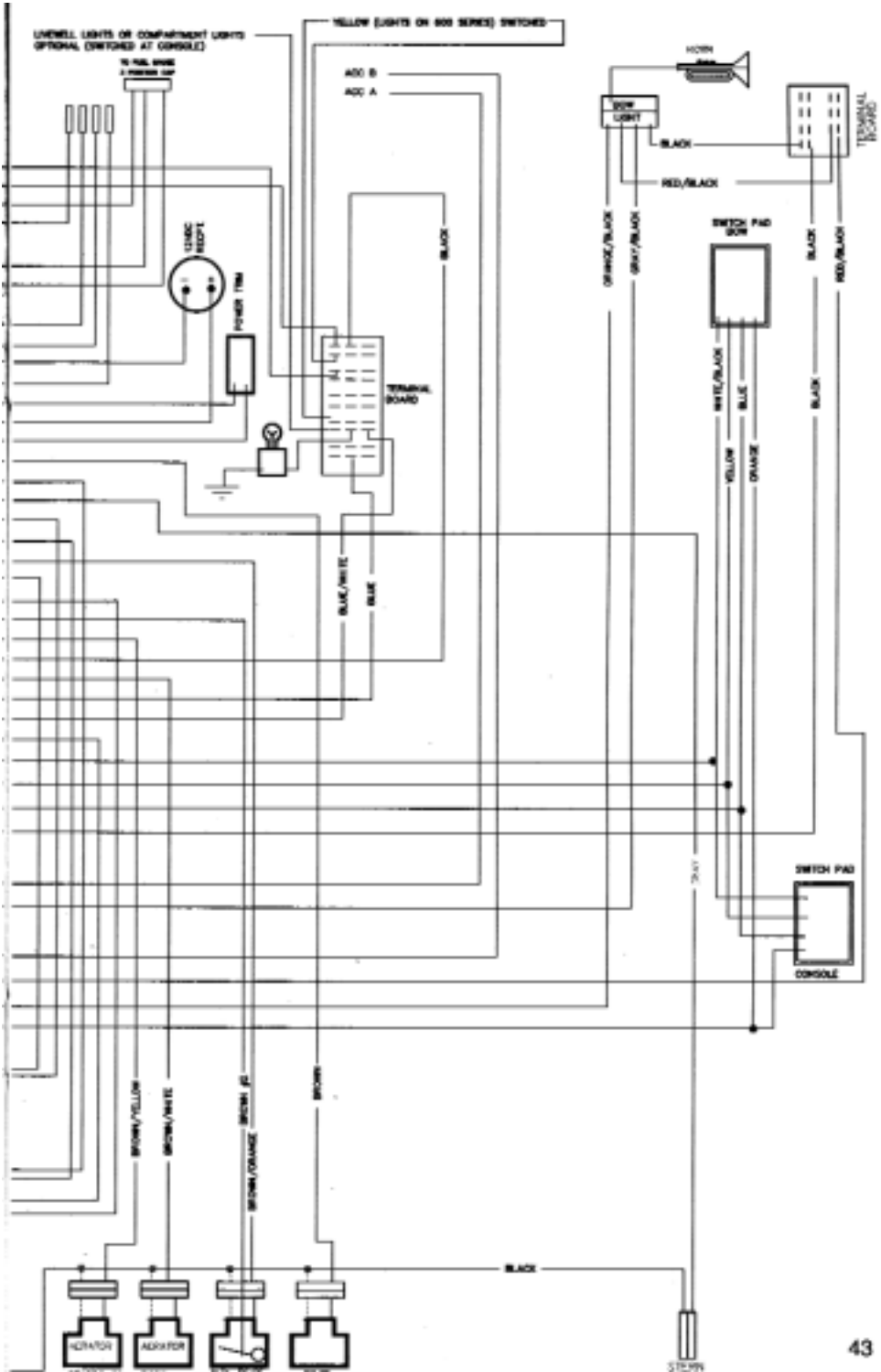

# SALTWATER SERIES



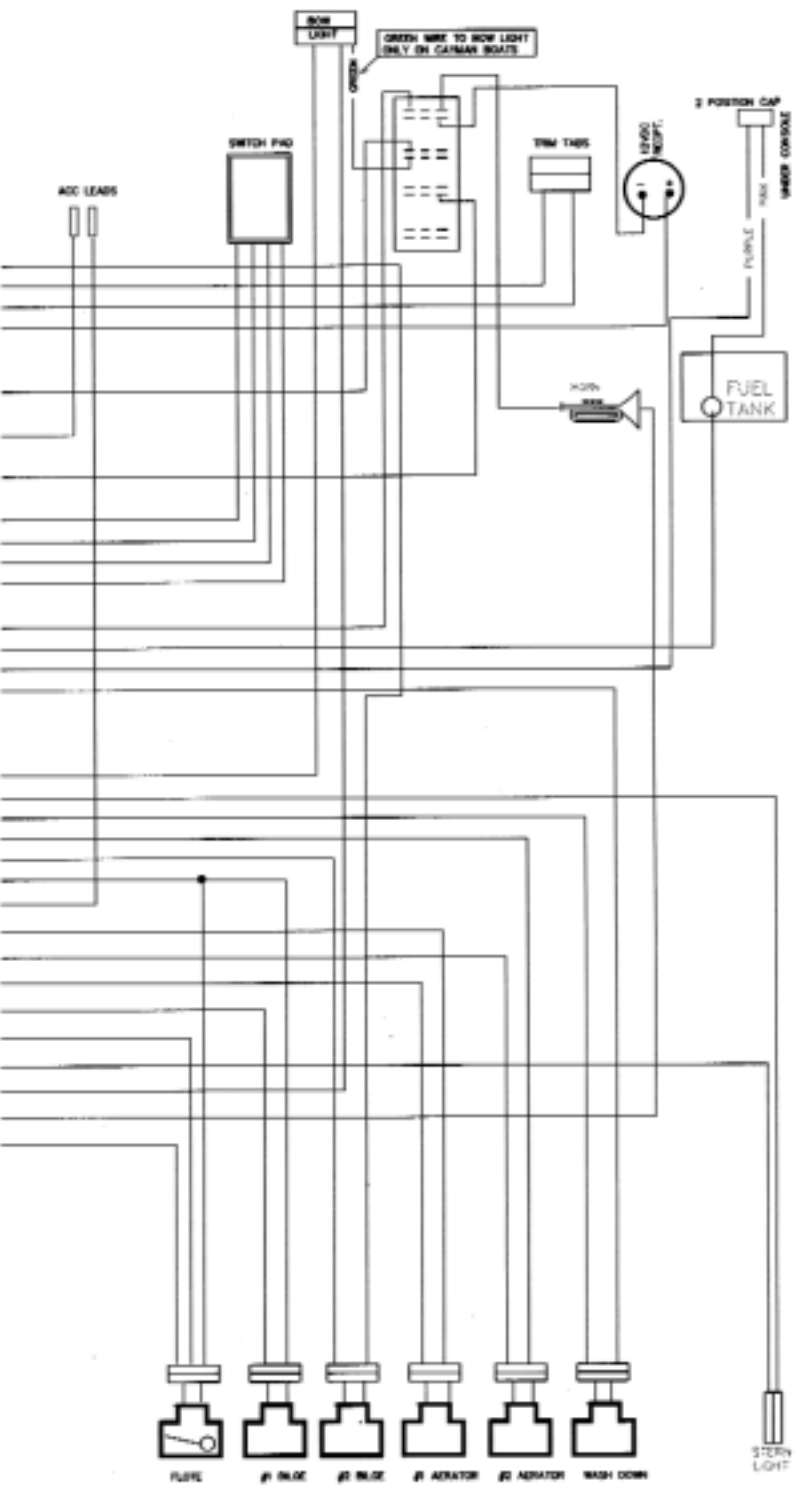

## **ELECTRICAL SYSTEM**

### **FUSE PANEL INFORMATION**

The fuse panel, located for easy access, features plug-in type ATC fuses. The fuses can be easily inspected or replaced.

The panel has a capacity of twelve to sixteen individual circuits. The particular accessory(ies) they operate are shown on the decal on the right side of the fuse panel or back side of fuse panel cover.

 **CAUTION** Do not exceed recommended fuse sizes. Always install proper rated fuse when adding accessories to the fuse panel.

## **FISHERMAN SERIES**

### **Navigation and Anchor Lights**

The switch that is labeled “Lights” on the bow and console keypads controls the operation of these lights. On the first key press the Navigation and Anchor Lights turn on. On the second key press the Navigation Lights turn off and the Anchor Lights remain on. On the third key press the Anchor lights turn off.

### **Aerator System**

The switches labeled “Aerator Pumps” and “Aerator Timer” on the bow and console keypads control the Aerator System. Pressing the “Aerator Pumps” switch once turns on aerator pump #1. Press a second time and pump 1 turns off and pump 2 turns on. Press a third time and both pumps are turned on. The pumps will remain on continuously until the “Aerator Pumps” switch is pressed for the fourth time. When the pumps are turned on the “Aerator Timer” switch can be used to start a timed aeration cycle. Pressing the “Aerator Timer” switch once starts the low aeration cycle of 1 minute on and 2 minutes off. Pressing the switch a second time starts the medium aeration cycle of 5 minutes on and 2 minutes off. The third press starts the high aeration cycle of 15 minutes on and 2 minutes off. The fourth key press will turn off the timer function.

### **Fuel Level**

The switch labeled with a diagram of a fuel pump on the console keypad, controls which tanks fuel level is displayed on the fuel gauge. When the “Fuel” switch is pressed this will toggle between tank number 1 and tank number 2. Only tank position number 1 is used on Fisherman series and toggling to number 2 will cause the gauge to read empty.

### **Bilge System**

The switch labeled “Bilge” on the console keypad controls the Bilge System. The default condition for the bilge system is power applied to the float switch. Pressing the “Bilge” switch once turns on the manual bilge pump. Pressing a second time over-rides the float switch and turns on the auto-bilge pump. Pressing a third time turns off the manual bilge and the auto-bilge pumps and reactivates the float switch.

### **Interior Lights**

Pressing the switch labeled “Interior Lights” on the console keypad once turns on the interior lights. Pressing the switch again turns the lights off. Once the lights are turned on they will automatically shut off after 5 minutes.

### **Instrument Lights**

The switch labeled “Interior Lights” on the console keypad also controls the brightness for the instrument lights. Pressing and holding the switch for approximately 3 seconds will start to dim the instrument lights. The lights start at full brightness and dim down in 16 steps. After the 16 steps the instrument lights go back to full brightness. Once the brightness is set the system will remember the setting.

### **Accessories**

There are 5 accessory functions on the system. Accessories 1-3 on the console keypad and Accessories A and B on the bow keypad. Pressing the corresponding switch once will turn on that accessory. Pressing the corresponding switch again will turn off that accessory.

### **Horn**

From the console keypad press and hold for operation and release to stop.

### **Trim**

On the bow keypad the switch with the “Up Arrow” controls the trim up and the switch with the “Down Arrow” controls the trim down. Press and hold the switch to either raise or lower the main engine.

### **Back Lighting**

The back lighting will turn on for 60 seconds when any key is pressed and the ignition is in the “off” position. The back lighting is on when the ignition is in the “on” position.



## **COMANCHE SERIES**

### **Navigation and Anchor Lights**

The switch that is labeled “Lights” on the bow and console keypads controls the operation of these lights. On the first key press the Navigation and Anchor Lights will turn on. On the second key press the Navigation Lights turn off and the Anchor Lights remain on. On the third key press the Anchor lights turn off.

### **Aerator System**

The switches labeled “Aerator Pumps” and “Aerator Timer” on the bow and console keypads control the Aerator System. Pressing the “Aerator Pumps” switch turns on both aerator pumps. The pumps will remain on continuously until the “Aerator Pumps” switch is pressed again. When the pumps are turned on the “Aerator Timer” switch can be used to start a timed aeration cycle. Pressing the “Aerator Timer” switch once starts the low aeration cycle of 1 minute on and 2 minutes off. Pressing the switch a second time starts the medium aeration cycle of 5 minutes on and 2 minutes off. The third press starts the high aeration cycle of 15 minutes on and 2 minutes off. The fourth key press will turn off the timer function.

### **Fuel Level**

The switch labeled with a diagram of a fuel pump on the console keypad, controls which tanks fuel level is displayed on the fuel gauge. When the “Fuel” switch is pressed this will toggle between tank number 1 (starboard) and tank number 2 (port). On Models with only 1 fuel tank, the number 2 position will cause the gauge to read empty.

### **Bilge System**

The switch labeled “Bilge” on the console keypad controls the Bilge System. The default condition for the bilge system is power applied to the float switch. Pressing the “Bilge” switch once turns on the manual bilge pump. Pressing a second time over-rides the float switch and turns on the auto-bilge pump. Pressing a third time turns off the manual bilge and the auto-bilge pumps and reactivates the float switch.

### **Interior Lights**

Pressing the switch labeled “Interior Lights” on the console keypad once turns on the interior lights. Pressing the switch again turns the lights off. Once the lights are turned on they will automatically shut off after 5 minutes.

### **Instrument Lights**

The switch labeled “Interior Lights” on the console keypad also controls the brightness for the instrument lights. Pressing and holding the switch for approximately 3 seconds will start to dim the instrument lights. The lights start at full brightness and dim down in 16 steps. After the 16 steps the instrument lights go back to full brightness. Once the brightness is set the system will remember the setting.

### **Accessories**

There are 5 accessory functions on the system. Accessories 1-3 on the console keypad and Accessories A and B on the bow keypad. Pressing the corresponding switch once will turn on that accessory. Pressing the corresponding switch again will turn off that accessory.

### **Horn**

From the console keypad press and hold for operation and release to stop.

### **Trim**

On the bow keypad the switch with the “Up Arrow” controls the trim up and the switch with the “Down Arrow” controls the trim down. Press and hold the switch to either raise or lower the main engine.

### **Back Lighting**

The back lighting will turn on for 60 seconds when any key is pressed and the ignition is in the “off” position. The back lighting is on when the ignition is in the “on” position.

## **KEYLESS IGNITION**

2004 Comanche and Fisherman models may be rigged with keyless ignition. The user code for this system will come from the factory preset to 1-2-3-4.

### **To change from the preset to your personal user code:**

- 1) Enter the 1-2-3-4 code.
- 2) Press the 1 and 4 keys simultaneously then release
- 3) The "Start" LED will blink
- 4) Enter your new 4 digit user code followed by pushing the "Start" key
- 5) Enter your new 4 digit user code again then push the "Start" key
- 6) The "Start" LED will burn steady and the system will be in the accessory mode

### **To start and stop the engine:**

- 1) Enter your user code (the "Start" LED will burn steady)
- 2) Press and hold the "Start" key for engine cranking, release to stop cranking
  - \* Note - During cranking, the 1 key can be used for engine choking if necessary
- 3) To turn off the engine, press the "Stop" key
- 4) To restart the engine, press and hold the "Start" key

### **To turn off and lock the key pad:**

- 1) Enter your user code
  - 2) Press the "Stop" key
- Note – If the system is left in run mode for longer than 10 hours without a key press, the system will go into the locked mode

## **SALTWATER SERIES**

### **Navigation and Anchor Lights**

The switch that is labeled "Lights" controls the operation of these lights. On the first key press, the navigation and anchor will both come on. On the second key press, the navigation lights turn off and the anchor lights remain on. On the third press, the anchor lights turn off. The indicator brightness will dim when the navigation or anchor lights are on.

### **Aerator System**

The switches labeled "Aerator 1", "Aerator 2", and "Aerator Timer" control the aerator system. Pressing the "Aerator 1" switch turns on aerator 1. Likewise, pressing the "Aerator 2" switch turns on aerator 2. The pumps will remain on continuously until their corresponding switch is pressed again. When the pumps are on, the "Aerator Timer" switch can be used to start a timed aeration cycle. Pressing the "Aerator Timer" switch once starts the low aeration cycle of 1 minute on and 2 minutes off. Pressing the switch a second time starts the medium cycle of 5 minutes on and 2 minutes off. The third press starts the high aeration cycle of 15 minutes on and 2 minutes off. A fourth press of the switch will turn off the timer function.

### **Bilge System**

The switch labeled "Auto Bilge" controls the bilge pump system. Pressing the "Auto Bilge" switch once turns on the bilge pump. Pressing the switch a second time turns off the pump.

### **Accessories**

There are 4 accessory functions labeled "ACC 1", "ACC 2", "ACC 3" and "ACC 4". Pressing the corresponding switch once will turn on that accessory. Pressing the same switch again will turn off that accessory.

### **Horn**

Press and hold for operation and release to stop

### **Back Lighting**

The back lighting will turn on for 60 seconds when any key is pressed and the ignition is in the off position. The back lighting is on when the ignition is in the on position.

### **Circuit Breaker Protection**

Each function is protected with a circuit breaker. If the circuit breaker trips, or there is a malfunction with the relay which results in a lack of power at the output pin of the box, then the corresponding indicator will flash quickly.

### INSTALLATION OF 4 PRONG "TYPE IV" PLUG TO TROLLING MOTOR AND BATTERY CHARGER

The Type IV plug is not designed for direct attachment to bare wires. All wires must be terminated with a #10 ring terminal of the appropriate wire gauge size. When assembling plug, insure that two cover screws pass through grooves in plug body.

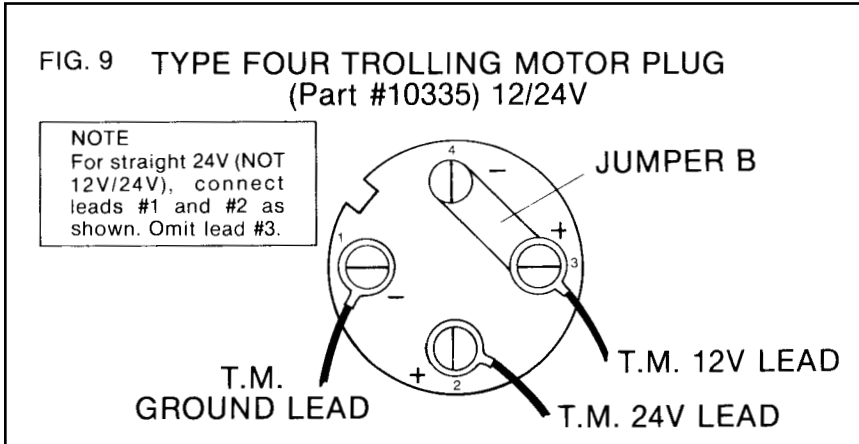

**CAUTION** Always disconnect trolling motor plug prior to any direct charging to any battery in the rear storage area.

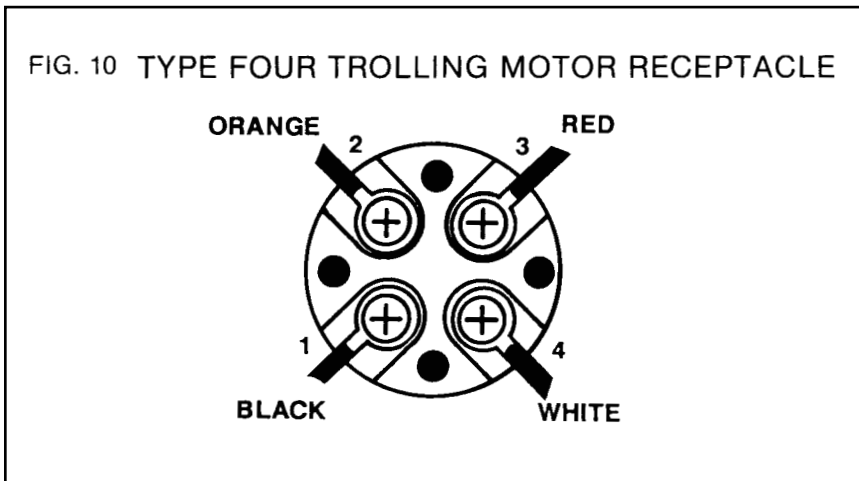

FIG. 11 TYPE FOUR TROLLING MOTOR PLUG  
(Part #10335) 12V

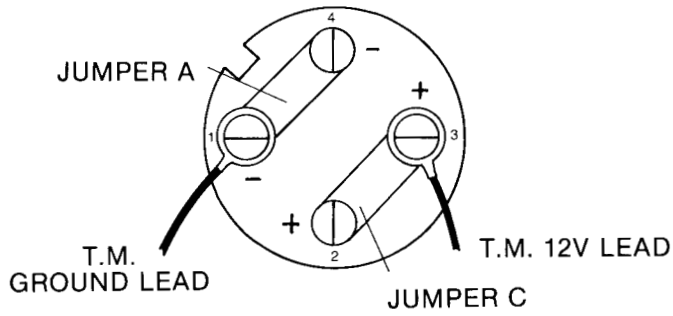

FIG. 12 TYPE FOUR BATTERY CHARGER PLUG  
(Part #10336) 12V

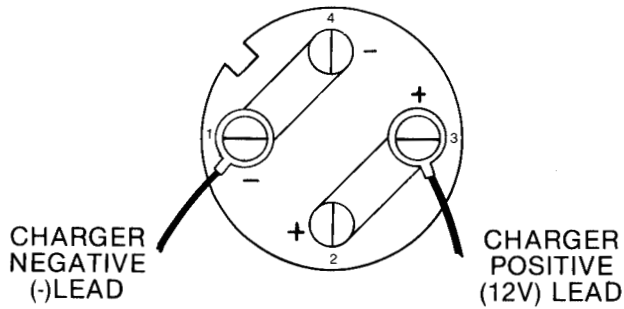
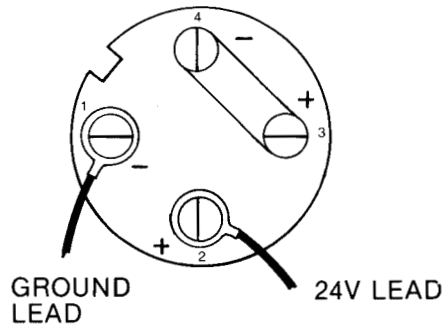

FIG. 13 TYPE FOUR BATTERY CHARGER PLUG  
24V



## **SAFETY AND MAINTENANCE TIPS**

- Check battery connections periodically to make sure they are corrosion free and TIGHT.
- Alterations of any part of the wiring system should be avoided! Such alterations could cause damage and/or electrical short.
- Inspect wiring connections and terminals periodically for corrosion, etc. and replace as needed. Replacement components should always be of equal or greater rating and quality. We recommend Ranger replacement parts available through your Ranger dealer.
- Always disconnect the positive and negative leads from the battery terminals before installing, removing, servicing, or troubleshooting any part of the electrical system.

<b>EQUIPMENT</b>	<b>CLASS A (Under 16' in Length)</b>	<b>CLASS I (16' , but under 26')</b>
Whistle or Horn	Must have means of making an efficient sound signal.	
Visual Distress	None Required During Daytime	All recreational boats, when used on coastal waters, which includes the Great Lakes, the Territorial Seas, and those waters directly connected to the Great Lakes and the Territorial Seas, up to a point where the waters are less than two miles wide, must be equipped with visual distress signals.
Lights	Proper light displays are required to be shown from sunset to sunrise.	
Fire Extinguishers	One B-1 U.S.C.G. or U.L. approved fire extinguisher unless the construction is such that explosive flammable vapors cannot be trapped, there are no closed compartments, no permanently installed fuel tanks on board.	
PFD'S	Type I, II, III, or V for each person aboard.	Type I, II, III, or V for each person aboard and one Type IV.
Numbering	All undocumented vessels equipped with propulsion machinery must be numbered in the state of principle use.	
Certificate of Number	A valid certificate of number showing the numbers issued to a vessel must be on board whenever the vessel is in use.	
Display of Number	Number must be painted or permanently attached to each of the forward halves of the vessel, and no other number may be displayed thereon.	

NOTE: The above information is not conclusive. The owner/operator should check all current Federal, State, and Local Regulations to insure compliance.



Boat operators are required to file a boating accident report with their state boating law enforcement agency when their boat is involved in certain boating accidents as follows:

- 1) There is loss of life or probable loss of life.
- 2) Personal injury requiring medical treatment (other than first aid).
- 3) Damage to property that exceeds \$500.

**BOAT DATA**

OWNER \_\_\_\_\_

Address \_\_\_\_\_

DEALER \_\_\_\_\_

Address \_\_\_\_\_

Phone \_\_\_\_\_

BOAT - MAKE/MODEL \_\_\_\_\_

Serial No. \_\_\_\_\_

Key No. \_\_\_\_\_

ENGINE - MAKE/MODEL \_\_\_\_\_

Serial No. \_\_\_\_\_

Drive Unit Serial No. \_\_\_\_\_

OTHER \_\_\_\_\_

\_\_\_\_\_

\_\_\_\_\_

\_\_\_\_\_

\_\_\_\_\_

\_\_\_\_\_

## GENERAL INFORMATION AND MAINTENANCE

- Keep the hubs properly lubricated at all times as described in the hub section of this manual.
- Check all lights before each use of the trailer.
- Check the tires for wear, cuts or other damage before each use and replace as needed. Check tire pressure often. See tire sidewall for maximum pressure and maximum load.
- Check lug nuts for tightness before use. Torque lug nuts to 75 ft. lbs.
- Periodically check the winch strap and winch parts for any wear and replace worn parts.
- Remember... a small expense for preventive maintenance is much less expensive now than a road-side breakdown later!

**⚠ CAUTION** Trailer tires should be properly inflated and maintained! The load-carrying capacity of your trailer is based on the tire pressure. Inadequate tire pressures can void your tire and trailer warranty and could also lead to an accident damaging to people or equipment!

**⚠ WARNING** Lug nuts should be properly tightened before each use. Failure to do so could result in loss of a wheel and could lead to an accident causing injury or death.

## **E-Z LUBE HUBS**

These hubs have a unique method of lubrication. The grease actually fills from the rear bearing and the back of the hub, forward to the outer bearing. Since the E-Z Lube Hub, properly maintained, lubricates the rear bearing first, all air is forced forward out of the hub, making for a more perfect seal.

The wheel bearings are lubricated via flush mount Zerk fittings in the end of the spindle. These bearings should be serviced every 10,000 miles or one (1) year.

To do so, jack up the trailer and remove the wheel. Remove the dust cap by lightly tapping with a hammer and screwdriver on the cap edge where it meets the hub. Using a grease gun with a needle attachment (available at most parts stores), place the needle in the Zerk and pump until new grease appears around the outside bearing. Remove excess grease from bearings and cap, then reinstall the cap with a gasket sealer around the sealing lip. Drive the dust cap in place with a rubber hammer and reinstall wheel.

## **COOL HUBS**

Contained Oil Orbital Lubrication (COOL) Hubs feature:

- **ADDING LUBRICANT** - Lubricant is added through threaded port on nose of hub. This allows for easy access and maximum filling of hub cavity with oil.
- **LUBRICANT** - Uses standard 50 weight motor oil.
- **PRESSURE CONTROL-THERMAL EXPANSION** - Hub cavity is completely filled with oil. There is no void which could allow water entry during submersion of trailer in water and cooling of oil.
- **SEALING - FRONT** - Stainless steel barrel is press fit into hub. A seal is used between hub bore and barrel. Double quad-rings on piston riding on a stainless steel surface to help prevent any leakage.
- **SEALING - REAR** - A factory installed stainless steel collar is press fitted and sealed onto spindle. A coated double lip inner hub seal riding on the stainless steel collar keeps pressurized oil in and water out of hub.

If your trailer is equipped with COOL Hubs, the system should be serviced once a year or every 20,000 miles whichever comes first. To do so, simply remove the plug located in the hub nose, rotate the hole to the bottom position to drain the oil, refill the hub completely with approximately 5 oz. of 50 wt, standard (non-synthetic) motor oil and reinstall plug.

## TRAILER BRAKES

If your trailer is equipped with brakes, follow the safety and maintenance tips listed below for best service.

- Always hook up the brake breakaway cable securely to the tow vehicle (should the trailer come loose, cable will activate the brakes to help slow runaway trailer). Before towing, reset the breakaway cable release lever by pushing up on the lever to release any pressure that may have inadvertently been applied to the brake system (Fig. 15, page 63). Always insert hitch pin after latching coupler to trailer ball (Fig. 15, page 63).
- Disc brake trailers are equipped with an electric solenoid valve to prevent the disc brakes from being activated while reversing your trailer. Disc brakes will operate at full capacity in either direction. It is therefore, essential that the wire from the solenoid valve be connected to the reverse light wire of the tow vehicle. When the tow vehicle is put in reverse gear, the solenoid will deactivate the brakes and allow you to back up (Fig. 16 page 63).

To check proper operation of solenoid valve, place tow vehicle gear shift in reverse (with engine shut off and ignition on). Backup lights should turn on and an audible “click” should be heard at the valve. If lights come on and no “click” is heard, check for an electrical wiring or connection problem.

**⚠ CAUTION** Make sure back up lights **do not** come on when tow vehicle transmission is in any gear other than reverse.

- Check cap of master cylinder often for tightness.
- Follow routine maintenance and inspection for disc brakes as outlined in your Disc Brake Manual.

To minimize corrosion, it is necessary for the disc brake calipers and rotors to be rinsed off with fresh water after trailer has been immersed in salt water.

## INSPECTION

To assure continued proper operation of our trailer disc brakes, annual inspection is recommended.

## BRAKE LOCKOUT INSTRUCTIONS

Brake lockout is useful in situations where you need to back over soft ground or up a hill while electric solenoid is disconnected.

- When hitch is fully extended, press down reverse lockout cap and turn clockwise to manually lockout brakes (see Fig. 14, below). Lockout should return to normal position under forward pressure.
- Press down and turn counter-clockwise to remove reverse lockout cap to check brake fluid.

FIG. 14

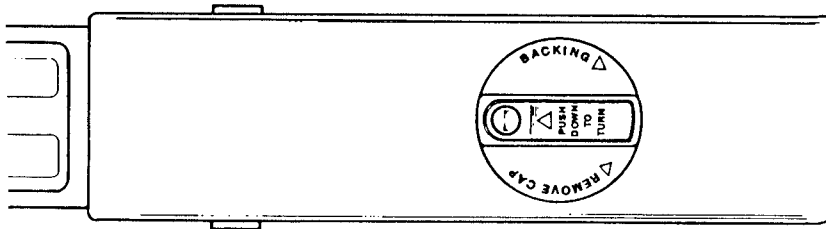

FIG. 15

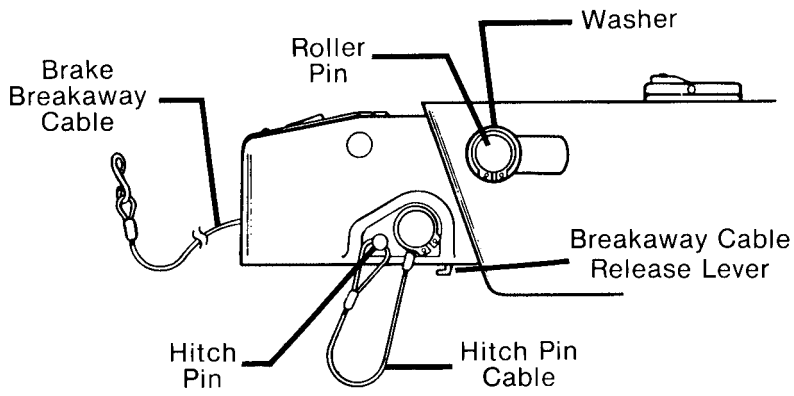
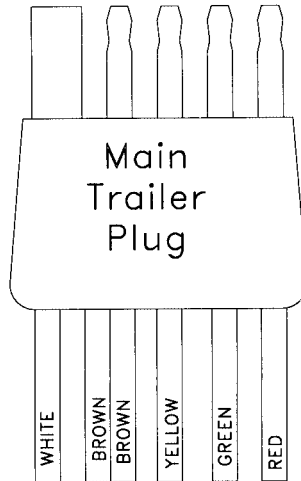

FIG. 16

### RANGERTRAIL WIRING

- WHITE - Ground
- BROWN - Tail & Clearance lights
- YELLOW - Left stop & turn lights
- GREEN - Right stop & turn lights
- Red - To back-up light wire on vehicle



**DB 42 DISC BRAKE PARTS LIST**

#	Part No.	Qty./Axle	Description
1	33640	2	HUB/ROTOR ASSEMBLY
2	36020	2	CALIPER BODY ASSEMBLY
3	33015	1	BRAKE PAD SET (Inner shown)
4	33015	-	BRAKE PAD SET (Outer shown)
5		1	AXLE WITH BRAKE FLANGE
6	36045	2	MOUNTING BRACKET
7	32372	2	GREASE SEAL, #233-168-SP2
8	32351	2	BEARING CONE, INNER, L-68149
9	32350	2	BEARING CONE, OUTER, L-44649
10	32409	8	7/16"-20 X 1" BOLT
11	32410	8	7/16" LOCK WASHER
12	32411	8	7/16" HEX NUT
13	36075	4	SPRING CLIP
14	32500	2	BLEEDER SCREW
15	32307	2	BANJO BOLT
16	32275	2	BANJO FITTING
17	32230	4	COPPER WASHER
18	33020	2	5/16"-18 X 2-1/2" BOLT

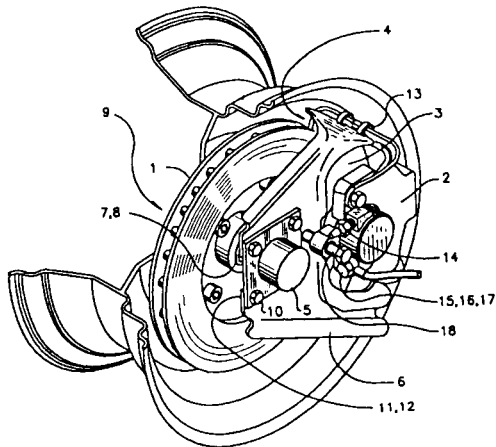



## **PADS**

Pads must be replaced when 1/16 inch (0.060") of pad friction material is left.

**⚠ CAUTION** If not familiar with disc brake pad replacement, have work performed by a qualified individual or service shop.

## **ROTORS**

Rotors should be resurfaced by a qualified brake specialist if extreme galling or wear marks are present.

**⚠ CAUTION** Rotors must be replaced if distance between brake surfaces becomes less than 0.882 inches (22.4mm) due to wear or machining.

## **RUST**

Check for extreme rust on mounting bolts, flanges and welds, which may weaken the structural integrity of the system. Repair or replace as necessary.

## **LEAKS**

**⚠ CAUTION** Check for leaks in the brake lines and fittings. Leaks will lead to loss of trailer braking ability. Repair or replace as necessary.

## **REPLACEMENT PARTS**

All replacement parts can be purchased from **Unique Functional Products**, 135 Sunshine Lane, San Marcos, CA 92069. If you have any questions or problems with the disc brakes, please write or call Unique Functional Product's customer service department at 1-800-854-1905 or in California 1-800-542-6400.

**⚠ WARNING** The braking mechanism on this trailer is designed as an aid in slowing and stopping the trailer. The braking system on the tow vehicle is the primary slowing and stopping system. You will not be able to stop the tow vehicle and the towed trailer as quickly as you could stop the tow vehicle alone.

## REMOVABLE TONGUE

The removable tongue option was made available for those with limited storage space for their boat and trailer. Its design uses 2 hitch pins to secure the coupler slide assembly to the receiver. Do not, under any circumstances, tow your trailer without both pins inserted completely through the slide and receiver.

If your trailer is equipped with brakes, the hydraulic connection is made behind the winch stand support bar. (Refer to Figure 17 below.) Failure to make this connection will result in no braking action and could lead to the brakes locking up due to heat buildup in the closed system. The wiring harness connection is also made in this area. To remove the coupler, support the trailer on the swing away jack stand. Disconnect the wire harness and brake line (if so equipped). Remove the two hitch pins and slide the coupler forward and out of the receiver.

**⚠ WARNING** When installing the coupler, be sure to install both hitch pins and connect the brake line and/or the wire harness before towing. Failure to do so could lead to an accident resulting in injury or death.

FIG. 17

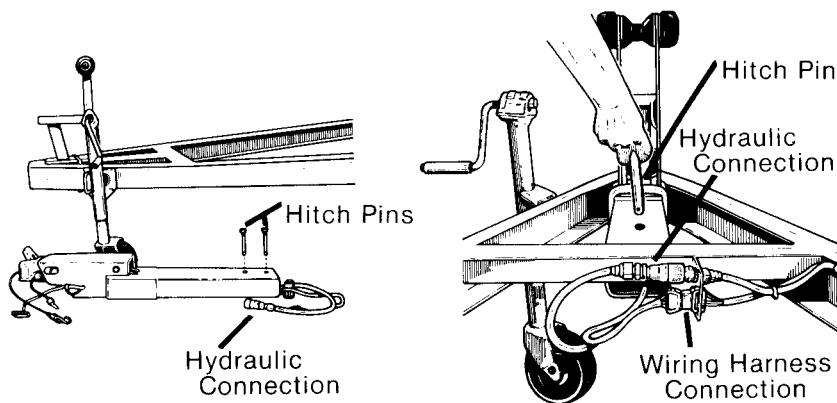

## SWING HITCH



To operate the swing hitch, pull the pin out of the bottom of the T-handle pin, fold up the safety catch on the bottom of the T-handle pin, pull the T-handle pin out of the frame and the hitch can now be swung to the side. When returning the hitch to the tow position the T-handle pin and the safety pin must be installed. **NEVER TOW YOUR TRAILER WITHOUT THE T-HANDLE PIN AND THE SAFETY PIN INSTALLED!**

### **BEFORE TOWING YOUR RANGERTRAIL® TRAILER . . .**

Make sure that your tow vehicle is equipped with a **2-inch ball** of machined or forged steel! **Never** use a ball smaller than 1.97 inch diameter or larger than 2.0 inch diameter. Naturally, your tow vehicle should be equipped with a properly rated and substantial towing hitch, well braced and firmly connected to your vehicle. Make sure that your vehicle is properly wired for the trailer light connection.

The height of the towing ball above the ground will greatly influence the tongue weight and the towing characteristics of the trailer. With the trailer attached to the tow vehicle, the base of the ball should be approximately 16" from the ground.

### **TOWING YOUR RANGER TRAIL® TRAILER . . .**

Back your tow vehicle into position so that the ball is directly under the trailer hitch ball socket. Stop your vehicle's engine and set parking brake. Make sure that the release handle on the trailer hitch is raised and pulled to the rear. This will show that the ball socket is open and ready to receive the tow ball. Then, by turning the tongue jack handle, lower the hitch until it seats

fully on the tow ball. Be sure that the tongue jack wheel is slightly clear of the ground. Close the ball socket latch by pushing downward into the recess. The release handle should close smoothly if the ball has been seated correctly into the socket. If the release handle does not close, **DO NOT TOW THE TRAILER**. To make sure that the connection is secure, lower the tongue jack until the ram has lifted the trailer hitch and trailer tongue connection 3 or 4 inches. If the ball does not disengage, you may be reasonably sure that the attachment is secure.

Next, fully retract the jack into the full up position and connect the safety chains to the connection points on your tow vehicle hitch.

If your trailer is equipped with brakes, hook up the breakaway cable, reset the breakaway cable release lever by pushing up on the lever and insert the coupler hitch pin as shown in the brake owners manual. If you do not have a manual for your brake system, please call or write Unique Functional Products, 135 Sunshine Lane, San Marcos, California 82069, 1-800-854-1905 or in California 1-800-542-6400.

On swing hitch trailers, make sure that the hitch is forward and the locking pin is properly installed. If you have a removable tongue trailer, make sure the two hitch pins holding the coupler slide assembly in the receiver are properly installed and seated (figure 17, pg. 66). If both pins are not inserted through the assembly, do not tow your trailer.

On removable tongue trailers with brakes, there is a hydraulic connection that must be made in order for the brakes to work. This is a push together, quick connect type fitting. Failure to make this connection will result in no braking assistance from the trailer. Hook up the wire harness (two places on the removable tongue), and check that all lights are operating properly. Test your vehicle lights to make sure that the trailer's brake and turn signals duplicate your vehicle's. Remove any trailer wheel chock and carefully drive off.

 <b>CAUTION</b>	Retract jack fully before towing! Replace coupler and ball if worn... do not attempt repair or adjustment.
--	--

To unhitch your trailer from the tow vehicle, place the trailer on a level and paved surface and chock both trailer wheels to prevent any movement forward or backward. Unhook the safety chains, wiring harness and, if so equipped, the brake break-away cable. Then, using the trailer tongue jack, raise the hitch up and clear the ball. In this position the trailer tongue should be left somewhat bow high so that any water will run out through the drain hole in the stern of the boat.

---

**RANGERTRAIL® PARTS LIST**

<b>#</b>	<b>DESCRIPTION</b>
1.	A-60 Inner Member
2.	Bow Roller Assembly
3.	Winch Stand (specify serial number)
4.	1400# Fulton Winch with Strap
5.	1200# Fulton Swing Jack
6.	Front Step Pad (specify serial number)
7.	Stop / Turn Light
8.	License Plate Lights
9.	I.D. Bar Light
10.	Black Keel Roller
11.	1/8" x 1-1/4" Cotter Key
12.	Wear Sleeve O-Ring
13.	L-Ring Wear Sleeve
14.	Grease Seal (AD2527E)
15.	Inner Bearing (L68149)
16.	Inner Bearing Race (L68110)
17.	Non Brake Hub with Races and Studs
18.	1/8" - 27 Pipe Plug
19.	Outer Bearing Race
20.	Outer Bearing (L68149)

RANGERTRAIL® PARTS

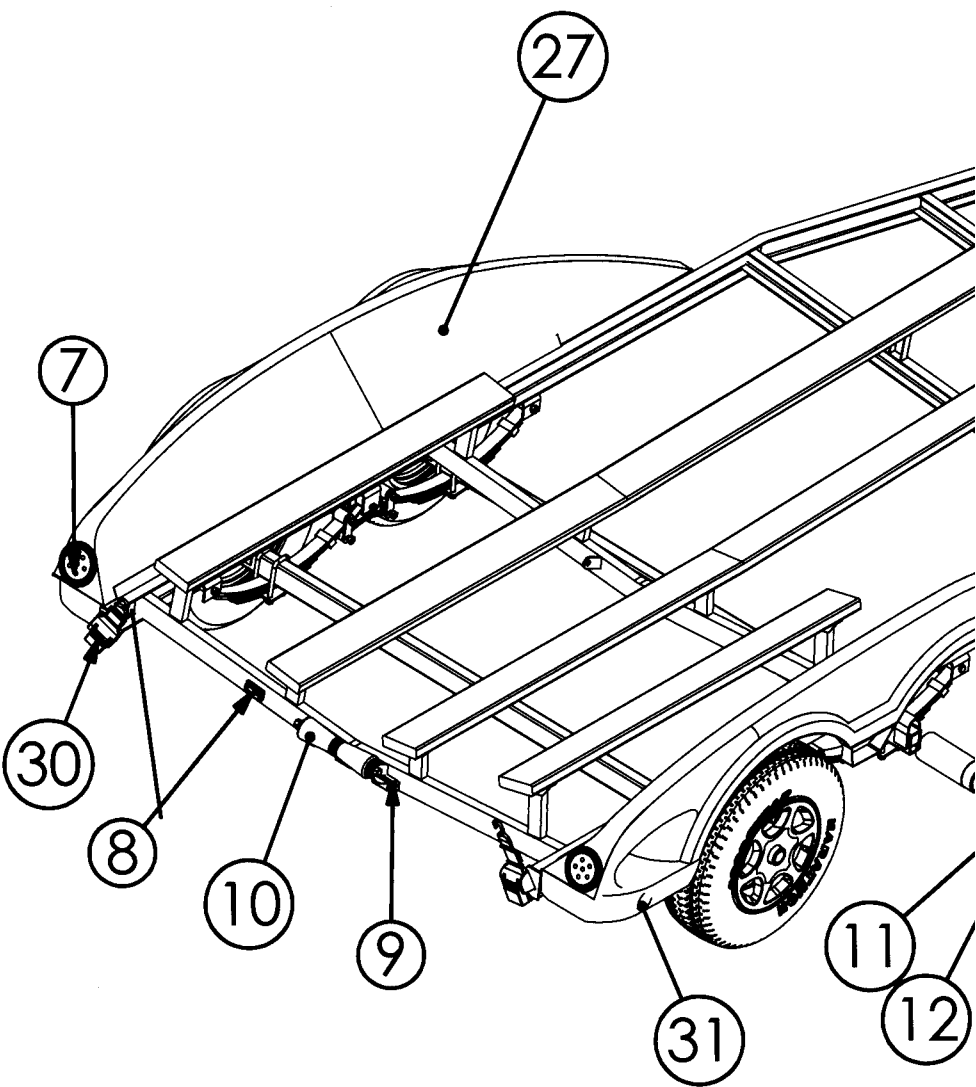

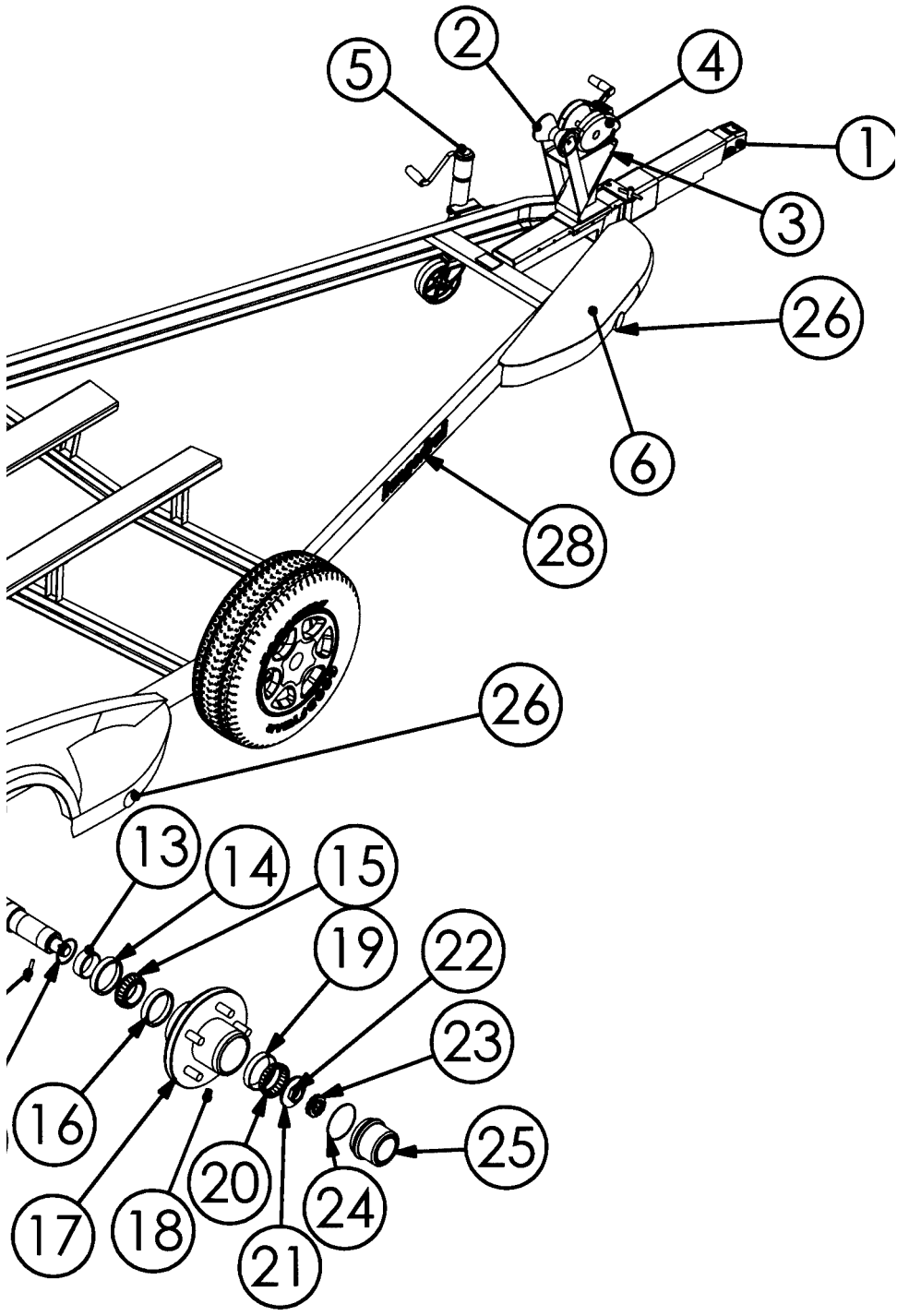

---

**RANGERTRAIL® PARTS LIST**

---

**# DESCRIPTION**

---

- |     |   |
|-----|---|
| 21. | Spindle Washer (2" Diameter)                |
| 22. | 13/16" - 20 Spindle Nut                     |
| 23. | Spindle Nut Retainer                        |
| 24. | Bearing Bath Cap O-Ring                     |
| 25. | Bearing Bath Cap                            |
| 26. | Amber Side Marker Light                     |
| 27. | Ranger Trail Fender (specify serial number) |
| 28. | Ranger Trail Decal (Black or White)         |
| 29. | Amber Wedge Light                           |
| 30. | Boat Buckle Tie Downs                       |
| 31. | Red Side Marker Light                       |



**WOOD MANUFACTURING COMPANY, INC. LIMITED WARRANTY**  
**RANGER® BOATS AND RANGERTRAIL® TRAILERS**  
**LIMITED WARRANTY**  
**(FIBERGLASS BOATS)**

"Wood Manufacturing Co., Inc., ("Wood"), warrants to you, the first North American retail purchaser of this 2004 model year boat delivered by a factory authorized dealer, that it will repair or replace defects in materials or workmanship that occur within the applicable warranty periods, subject to the "What This Warranty Does Not Cover" section below. The applicable Warranty Period runs from the date of delivery to the first retail customer provided that the boat is delivered within eighteen (18) months from the date of manufacture. For boats delivered more than eighteen (18) months after the date of manufacture, coverage will run from the date of manufacture and the first retail purchaser will be entitled to the coverage remaining under the Warranty Periods. All warranties run concurrently.

Defects in structural parts, including the hull, stringers and transom: Warranty Period runs for the duration of the original (1st) purchaser's period of ownership. The transferred Warranty Period to a 2nd purchaser runs ten (10) years from the original delivery date, regardless of when the warranty is transferred.

Defects in the following factory installed parts and components: Warranty Period runs for three (3) years.

1. Carpet fading
2. Steering helm, cylinder, hoses and cables
3. Aeration pumps, valves and timer
4. Boat electrical system
5. Seat pedestals
6. Fuel tanks
7. Deck hardware such as locks, cleats and fasteners
8. Factory installed battery chargers
9. RangerTrail® trailers

Remaining factory installed parts and components: Warranty Period runs one (1) year from the date of delivery to the original retail purchaser.

Defects in the exterior cosmetic gelcoat finish (cracking, crazing or fading): Warranty Period runs one (1) year from the date of delivery to the original retail purchaser. Repairs will only be authorized after Wood is satisfied that there is a defect in material or workmanship.

Coverage remaining under the Warranty Periods may be transferred by an authorized Ranger® dealer to a 2nd purchaser for a \$100 fee. The transfer must occur within five (5) years of the original retail sale. The transfer fee must be paid within 15 days of purchase of the used boat to transfer the warranty. Proof of purchase date is required. The warranty may only be transferred **once**.

NOTE: Wood will complete repairs covered under this warranty during the first year of ownership at no charge to the owner. After the first year, the owner must pay a deductible of \$50 per claim to the servicing dealer for service performed under this limited warranty.

Your sole and exclusive remedy is the repair or replacement, at Woods sole option, of parts and components covered by this warranty.

This Ranger® boat, including any alleged defective part, must be returned to an authorized Ranger® dealer within the applicable warranty period to obtain warranty service. The Ranger® dealer will carry out the warranty procedures on the owner's behalf. All warranty work will be performed at an authorized dealer, at the Wood factory, or at another repair facility that Wood selects. The owner is responsible for the expense associated with transporting the boat to and from the repair facility.

An action for breach of warranty shall be barred unless it is commenced within four (4) years from the date the cause of action accrues. An action for breach of any duty or obligation to repair or replace shall be barred unless it is commenced within one year from the date the cause of action accrues regardless of the time remaining in the Warranty Period.

**What This Warranty Does Not Cover:**

1. A boat including its components that has been altered or modified so as to adversely affect its operation, performance or durability.
2. Any damage resulting from an impact with another object.
3. Windshield breakage and leakage around windshields, hatches or other designed openings.
4. Gelcoat finishes including blistering, cracking, crazing, fading, chalking or discoloration (except as noted above).
5. Carpet and upholstery wear, fraying or tearing.
6. A boat which has been overpowered according to the maximum recommended engine horsepower specified on the capacity plate, or which has been altered by the use of a transom bracket or jack plate that is in excess of six (6) inches.
7. Estimated characteristics such as weight, speed and fuel consumption.
8. Any boat which has been misused, used in a negligent manner, used for racing, used for rental or other commercial purposes, used without normal maintenance, operated contrary to any instruction furnished by Wood, involved in an accident or operated in violation of any Federal, State, Coast Guard or other governmental agency laws, rules or regulations.
9. Loss of time, inconvenience, boat payments, retail charges, travel expense, loss of use, haul out, launch, towing and storage charges, loss of or damage to personal property, or other remedies not specifically allowed.
10. Dealer preparation, cleaning, final adjustments and alignments in preparing the boat for delivery.
11. Trailer tires, paint, corrosion, axle alignment, adjustments and trailer components manufactured by companies other than Wood.
12. Engines, outdrive, controls, propellers, batteries and other equipment or accessories that are not manufactured by Wood, whether or not warranted by other manufacturers.

Remedy under this warranty is expressly limited to repair or replacement of defects in materials or workmanship, **and does not include incidental or consequential damages**, which are specifically **DISCLAIMED**. Note: SOME STATES DO NOT ALLOW THE EXCLUSION OR LIMITATION OF INCIDENTAL OR CONSEQUENTIAL DAMAGES, SO THE ABOVE LIMITATION OR EXCLUSION MAY NOT APPLY TO YOU. The express limited warranty described above is exclusive. IMPLIED WARRANTIES (IF ANY), **INCLUDING MERCHANTABILITY AND FITNESS FOR A PARTICULAR PURPOSE**, ARE LIMITED IN DURATION TO THE APPLICABLE PERIOD OF THIS WRITTEN WARRANTY AND ARE EXPRESSLY DISCLAIMED AFTER THE EXPIRATION OF THE WARRANTY PERIOD. There are no warranties which extend beyond the description on the face hereof. **NOTE: SOME STATES DO NOT ALLOW LIMITATION ON HOW LONG AN IMPLIED WARRANTY LASTS, SO THE ABOVE LIMITATION MAY NOT APPLY TO YOU. THIS WARRANTY GIVES YOU SPECIFIC LEGAL RIGHTS WHICH VARY FROM STATE TO STATE.**

This document contains the entire warranty given by Wood. Wood does not authorize any person or persons, including Ranger® dealers, to change the terms of this express limited warranty, which is Wood's only warranty. Wood reserves the right to change or improve the design or manufacture of Ranger® boats without obligation to modify any boat previously manufactured.

**Wood Manufacturing Company, Inc.**  
**Highway 178 North**  
**P.O. Box 179**  
**Flippin, AR 72634**  
**870-453-2222**



